

STATE OF OHIO  
DEPARTMENT OF TRANSPORTATION

# GEA-87-2.73

## RUSSELL TOWNSHIP GEAUGA COUNTY

**PROJECT DESCRIPTION**

THIS PROJECT WILL REPLACE THE EXISTING SIGNAL SYSTEM, AND PROVIDE COUNTDOWN PEDESTRIAN SIGNAL HEADS AT THE INTERSECTION OF S.R. 87 AND S.R. 306.

**EARTH DISTURBED AREAS**

PROJECT EARTH DISTURBED AREA: 0.10 ACRES  
ESTIMATED CONTRACTOR EARTH DISTURBED AREA: 0.25 ACRES  
NOTICE OF INTENT EARTH DISTURBED AREA: N/A ACRES (NOI NOT REQUIRED)

**2019 SPECIFICATIONS**

THE STANDARD SPECIFICATIONS OF THE STATE OF OHIO, DEPARTMENT OF TRANSPORTATION, INCLUDING SUPPLEMENTAL SPECIFICATIONS LISTED IN THE PLANS AND CHANGES LISTED IN THE PROPOSAL SHALL GOVERN THIS IMPROVEMENT.

I HEREBY APPROVE THESE PLANS AND DECLARE THAT THE MAKING OF THIS IMPROVEMENT WILL NOT REQUIRE THE CLOSING TO TRAFFIC OF THE HIGHWAY AND THAT PROVISIONS FOR THE MAINTENANCE AND SAFETY OF TRAFFIC WILL BE AS SET FORTH ON THE PLANS AND ESTIMATES.

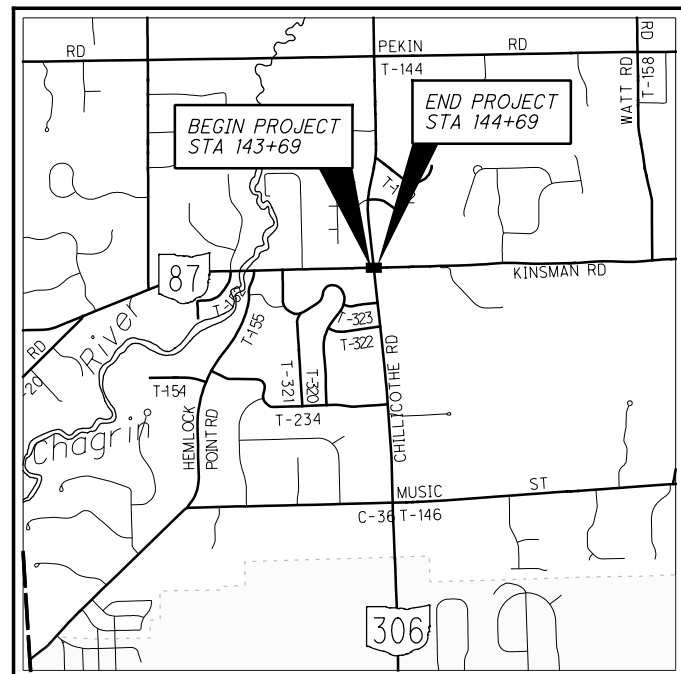

LOCATION MAP

LATITUDE: 41°27'50" LONGITUDE: 81°20'25"

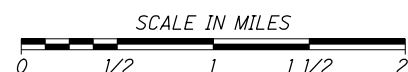

PORTION TO BE IMPROVED	-----	=====
INTERSTATE HIGHWAY	-----	=====
FEDERAL ROUTES	-----	=====
STATE ROUTES	-----	=====
COUNTY & TOWNSHIP ROADS	-----	=====
OTHER ROADS	-----	=====

**DESIGN DESIGNATION**

	<u>S.R. 87</u>
CURRENT ADT (2019)	6100
DESIGN YEAR ADT (2039)	6700
DESIGN HOURLY VOLUME (2039)	600
DIRECTIONAL DISTRIBUTION	52%
TRUCKS (24 HOUR B&C)	8%
POSTED SPEED	50 MPH
DESIGN FUNCTIONAL CLASSIFICATION:	MINOR ARTERIAL
NHS PROJECT	NO

**DESIGN EXCEPTIONS**

NON-REQUIRED

**INDEX OF SHEETS:**

TITLE SHEET	1
GENERAL NOTES	2-5
GENERAL SUMMARY	6
SUBSUMMARY	7
TRAFFIC CONTROL PLAN	8
TRAFFIC SIGNAL DEMOLITION PLAN	9
TRAFFIC SIGNAL PLANS	10-13, 11-11A, 12-12A
RIGHT OF WAY	14-20

**UNDERGROUND UTILITIES**  
Contact Two Working Days Before You Dig

**OHIO811.org**  
Before You Dig

OHIO811, 8-1-1, or 1-800-362-2764  
(Non-members must be called directly)

PLAN PREPARED BY:  
ENGINEERING ASSOCIATES, INC.  
1935 EAGLE PASS - WOOSTER OHIO  
TELEPHONE : (330) 345-6556

ENGINEERS SEAL:

SIGNED: *Scott A. Knebel*  
DATE: 09/18/2020

ENGINEERS SEAL:

SIGNED: \_\_\_\_\_  
DATE: \_\_\_\_\_

STANDARD CONSTRUCTION DRAWINGS				SUPPLEMENTAL SPECIFICATIONS	SPECIAL PROVISIONS
HL-30.11	7/17/20			800-2019 10/16/20	
HL-30.22	4/17/20			809 7/17/20	
				821 4/20/12	
				832 10/19/18	
				921 4/21/12	
TC-21.21	7/17/20				
TC-41.20	10/18/13				
TC-41.40	10/18/13				
TC-42.20	10/18/13				
TC-52.20	7/20/18				
TC-81.22	7/17/20				
TC-83.10	1/17/20				
TC-83.20	7/21/17				
TC-85.10	4/17/20				
TC-85.20	7/20/18				

APPROVED \_\_\_\_\_  
DATE \_\_\_\_\_ DISTRICT DEPUTY DIRECTOR

APPROVED \_\_\_\_\_  
DATE \_\_\_\_\_ DIRECTOR, DEPARTMENT OF TRANSPORTATION

L:\ODOT\19066303-00\_VAR-D12-D03-SftyDsgn\02\_GEA-87\110882\_Roadway\Sheets\110882\_GT001.dgn 9/21/2020 11:04:46 AM ghansel

FEDERAL PROJECT NO. **E191(631)**  
CONSTRUCTION PROJECT NO. **110882**  
RAILROAD INVOLVEMENT **NONE**  
**GEA-87-2.73**  
1/20

**UTILITIES**

LISTED BELOW ARE ALL UTILITIES LOCATED WITHIN THE PROJECT CONSTRUCTION LIMITS TOGETHER WITH THEIR RESPECTIVE OWNERS:

**GAS:**  
DOMINION ENERGY OHIO  
ATTN: MICAH J. RISACHER  
320 SPRINGSIDE DR.  
SUITE 320  
AKRON, OH 44333  
330-664-2409

**ELECTRIC:**  
ILLUMINATING COMPANY  
ATTN: JOHN M. ZASSICK  
6896 MILLER RD, SUITE 101  
BRECKSVILLE, OHIO 44141  
440-546-8706

**SEWER:**  
GEAUGA COUNTY WATER RESOURCES  
ATTN: GERARD R. MORGAN  
470 CENTER STREET, BUILDING #3  
CHARDON, OHIO 44024  
440-279-1970

**FIBER OPTIC:**  
WINDSTREAM  
ATTN: GEOFFREY HAMM  
560 TERNES AVE.  
ELYRIA, OHIO 44035  
440-329-4245

NORTHEASTERN ITS  
ATTN: JOHN BRUCE  
140 WINTER LANE  
CORTLAND, OH 44410  
877-601-7662

ODOT DISTRICT 12 TRAFFIC,  
5500 TRANSPORTATION BLVD.,  
GARFIELD HEIGHTS OH 44125,  
ATTN: KEITH HAMILTON, 216-584-2220,  
KEITH.HAMILTON@DOT.OHIO.GOV,  
ATTN: DAVID NIMRICHTER, 216-584-2296,  
DAVID.NIMRICHTER@DOT.OHIO.GOV

THE LOCATION OF THE UNDERGROUND UTILITIES SHOWN ON THE PLANS ARE AS OBTAINED FROM THE OWNERS AS REQUIRED BY SECTION 153.64 O.R.C.

**PROJECT DESCRIPTION**

THIS PROJECT CONSISTS OF UPGRADING THE EXISTING SIGNAL SYSTEM AT THE INTERSECTION OF S.R. 87 AND S.R. 306, WHICH INCLUDES THE INSTALLATION OF MAST ARMS, PULL BOXES, SIGNAL HEADS, CONTROLLER, RADAR DETECTION, AND COUNTDOWN PEDESTRIAN SIGNAL HEADS.

**UTILITIES**  
(SEE .DGN SHEET)

**SURVEYING PARAMETERS**  
(SEE .DGN SHEET)

**CLEARING AND GRUBBING**

ALTHOUGH THERE ARE NO TREES OR STUMPS SPECIFICALLY MARKED FOR REMOVAL WITHIN THE LIMITS OF THE PROJECT, A LUMP SUM QUANTITY IS INCLUDED IN THE GENERAL SUMMARY FOR ITEM 201, CLEARING AND GRUBBING. ALL PROVISIONS AS SET FORTH IN THE SPECIFICATIONS UNDER THIS ITEM ARE INCLUDED IN THE LUMP SUM PRICE BID FOR ITEM 201, CLEARING AND GRUBBING.

**CONSTRUCTION TRAFFIC**

USE ACCEPTABLE TRUCK ROUTES TO ACCESS THE CONSTRUCTION AREA FOR ALL CONSTRUCTION TRAFFIC. DO NOT USE LOCAL RESIDENTIAL STREETS UNLESS ALLOWED IN WRITING BY THE LOCAL ENFORCEMENT AUTHORITY.

**SURVEYING PARAMETERS**

PRIMARY PROJECT CONTROL MONUMENTS GOVERN ALL POSITIONING ON ODOT PROJECTS. SEE THIS SHEET FOR A TABLE CONTAINING PROJECT CONTROL INFORMATION.

USE THE FOLLOWING PROJECT CONTROL, VERTICAL POSITIONING, AND HORIZONTAL POSITIONING PARAMETERS FOR ALL SURVEYING:

**PROJECT CONTROL**

POSITIONING METHOD: GPS  
MONUMENT TYPE: IRON PINS

**VERTICAL POSITIONING**

ORTHOMETRIC HEIGHT DATUM: NAVD 88  
GEOID: GEOID 12B

**HORIZONTAL POSITIONING**

REFERENCE FRAME: NAD 83(2011)  
ELLIPSOID: GRS 80  
MAP PROJECTION: LAMBERT CONFORMAL CONIC  
COORDINATE SYSTEM: OHIO STATE PLANE, NORTH ZONE  
COMBINED SCALE FACTOR: NONE  
ORIGIN OF COORDINATE SYSTEM: 0.0, 0.0

USE THE POSITIONING METHODS AND MONUMENT TYPE USED IN THE ORIGINAL SURVEY TO RESTORE ALL MONUMENTS RELATED TO PRIMARY PROJECT CONTROL THAT ARE DAMAGED OR DESTROYED BY CONSTRUCTION ACTIVITIES. RESTORE THE DAMAGED OR DESTROYED MONUMENTS IN ACCORDANCE WITH CMS 623.

UNITS ARE IN U.S. SURVEY FEET.

**CONTINGENCY QUANTITIES**

THE CONTRACTOR SHALL NOT ORDER MATERIALS OR PERFORM WORK FOR ITEMS DESIGNATED BY PLAN NOTE TO BE USED "AS DIRECTED BY THE ENGINEER" UNLESS AUTHORIZED BY THE ENGINEER. THE ACTUAL WORK LOCATIONS AND QUANTITIES USED FOR SUCH ITEMS SHALL BE INCORPORATED INTO THE FINAL CHANGE ORDER GOVERNING COMPLETION OF THIS PROJECT.

**EQUIPMENT AND MATERIAL STORAGE**

IN ORDER TO PROVIDE FOR THE SAFETY OF THE TRAVELING PUBLIC THE CONTRACTOR'S ATTENTION IS DIRECTED TO 614.03. IN ADDITION, THE FOLLOWING PROVISIONS SHALL APPLY:

ANY REMOVED ITEMS SHALL NOT BE STORED ON THE RIGHT OF WAY FOR MORE THAN THIRTY (30) DAYS. THE STORAGE OF EQUIPMENT, MATERIALS, AND VEHICLES WITHIN THE HIGHWAY RIGHT OF WAY WILL BE PERMITTED. THE NUMBER OF AREAS AND EXACT LOCATIONS SHALL BE APPROVED BY THE ENGINEER. ALL DISTURBED AREAS SHALL BE RETURNED TO THEIR ORIGINAL CONDITION AT NO EXPENSE TO THE STATE.

**WORK LIMITS**

THE WORK LIMITS SHOWN ON THESE PLANS ARE FOR PHYSICAL CONSTRUCTION ONLY. PROVIDE THE INSTALLATION AND OPERATION OF ALL WORK ZONE TRAFFIC CONTROL AND WORK ZONE TRAFFIC CONTROL DEVICES REQUIRED BY THESE PLANS WHETHER INSIDE OR OUTSIDE THESE WORK LIMITS.

**COOPERATION BETWEEN CONTRACTORS**

IT IS ANTICIPATED THAT OTHER CONTRACTORS WILL BE WORKING ON PROJECTS ADJACENT TO OR WITHIN THE LIMITS OF THIS PROJECT, EITHER FOR THE DEPARTMENT OR FOR OTHER PUBLIC AGENCIES. COOPERATE AND COORDINATE OPERATIONS, INCLUDING PROVISIONS FOR THE MAINTENANCE OF TRAFFIC, WITH THE CONTRACTORS OF OTHER PROJECTS THAT MAY BE IN FORCE DURING THE LIFE OF THIS CONTRACT. SPECIFICALLY, ATTENTION SHOULD BE MADE TO SECTION 105.08 OF THE CONSTRUCTION AND MATERIALS SPECIFICATIONS. NO WAIVER OF ANY OF THE PROVISIONS OF SECTION 105.08 IS INTENDED.

**STAGING AREA**

THERE ARE NO SPECIFIC AREAS GIVEN IN THE PLANS FOR THE CONTRACTOR TO USE AS A STAGING AREA(S). IF THE CONTRACTOR WANTS TO USE AN AREA(S) FOR STAGING, REGARDLESS IF IT FALLS WITHIN THE PROJECT LIMITS OR NOT, THE CONTRACTOR IS TO USE THE RIGHT OF WAY E-PERMITTING SYSTEM AT [HTTPS://ODHCP.BEMCORP.NET/ACCOUNTS/ACCOUNT/ACCOUNT](https://odhcp.bemcorp.net/accounts/account/account) IN ORDER TO APPLY FOR A PERMIT PER SECTION 107.02 OF THE CMS. FOR SPECIFIC PERMITTING QUESTIONS, THE CONTRACTOR CAN CONTACT THE DISTRICT PERMITTING OFFICE, (MELVIN SAFFORD) AT 216-584-2137 OR AT [DISTRICT12PERMITS@DOT.OHIO.GOV](mailto:district12permits@dot.ohio.gov). IF A PERMIT IS GRANTED, ALL CONDITIONS OF THE PERMIT SHALL BE MET IN ADDITION TO THE REQUIREMENTS OF 104.04 OF THE CMS, AT NO ADDITIONAL COST TO THE STATE. IF THE PROJECT ENGINEER DEEMS THAT ALL THE CONDITIONS OF THE PERMIT WERE NOT MET, THEN 10% OF THE CONTRACT BID AMOUNT FOR MOBILIZATION SHALL BE WITHHELD UNTIL ALL THE CONDITIONS OF THE PERMIT ARE SATISFIED.

**RESTORATION OF DISTURBED AREAS**

THE CONTRACTOR SHALL RESTORE ALL DISTURBED LANDSCAPED AREAS, PAVEMENT SURFACES, SIDEWALKS (INCLUDING CURB RAMPS) AND DRIVEWAYS TO A CONDITION EQUAL TO OR BETTER THAN THAT EXISTING BEFORE THE WORK WAS STARTED. ALL RESTORATION SHALL BE PERFORMED WITH MATERIALS IDENTICAL TO THE EXISTING SURFACE INCLUDING BUT NOT LIMITED TO BITUMINOUS AND CONCRETE PAVEMENT, CONCRETE, SANDSTONE AND BRICK SIDEWALK, INTEGRAL CURB AND SPECIAL SURFACES (COLORED OR TEXTURED) AS ENCOUNTERED. CONCRETE SIDEWALK AND DRIVEWAYS SHALL NOT BE PATCHED, BUT SHALL BE REPLACED IN ENTIRE ORIGINAL SLAB SECTIONS.

ALL RESTORATION WORK SHALL BE DONE IN ACCORDANCE WITH THE PERTINENT SPECIFICATION ITEMS AND AS DIRECTED BY THE ENGINEER. PAYMENT FOR ALL RESTORATION WORK, INCLUDING MATERIALS, EQUIPMENT, LABOR, INCIDENTALS, AND DISPOSAL OF ALL SURPLUS MATERIALS SHALL BE INCLUDED IN THE VARIOUS ITEMS OF UNDERGROUND WORK AND, THEREFORE, NO SEPARATE PAYMENT WILL BE MADE FOR THIS WORK.

**NOTIFICATION OF CONSTRUCTION INITIATION**

AT LEAST FOURTEEN DAYS PRIOR TO ANY CONSTRUCTION ACTIVITIES, THE CONTRACTOR SHALL ADVISE THE DISTRICT OFFICE OF COMMUNICATIONS VIA EMAIL AT [D12.PUBLIC.INFORMATION@DOT.STATE.OH.US](mailto:d12.PUBLIC.INFORMATION@DOT.STATE.OH.US) OF THE ANTICIPATED START DATE OF ANY CONSTRUCTION ACTIVITIES, INCLUDING BUT NOT LIMITED TO THE PLACING OF WORK ZONE SIGNS. THE NOTIFICATION SHALL ALSO INCLUDE THE PROJECT NUMBER, PIO, NAME AND PHONE NUMBER OF THE CONTRACTOR, A POINT OF CONTACT, AND THE ANTICIPATED IMPACT ON TRAFFIC. THE CONTRACTOR WILL IMMEDIATELY INFORM THE DISTRICT OFFICE OF COMMUNICATIONS OF ANY AND ALL DELAYS AND/OR CHANGES REGARDING THE CONSTRUCTION INITIATION DATE.

**NOTIFICATION OF CONSTRUCTION INITIATION**

AT LEAST FOURTEEN DAYS PRIOR TO ANY CONSTRUCTION ACTIVITIES, THE CONTRACTOR SHALL ADVISE THE DISTRICT OFFICE OF COMMUNICATIONS VIA EMAIL AT [D12.PUBLIC.INFORMATION@DOT.STATE.OH.US](mailto:d12.PUBLIC.INFORMATION@DOT.STATE.OH.US) OF THE ANTICIPATED START DATE OF ANY CONSTRUCTION ACTIVITIES, INCLUDING BUT NOT LIMITED TO THE PLACING OF WORK ZONE SIGNS. THE NOTIFICATION SHALL ALSO INCLUDE THE PROJECT NUMBER, PIO, NAME AND PHONE NUMBER OF THE CONTRACTOR, A POINT OF CONTACT, AND THE ANTICIPATED IMPACT ON TRAFFIC. THE CONTRACTOR WILL IMMEDIATELY INFORM THE DISTRICT OFFICE OF COMMUNICATIONS OF ANY AND ALL DELAYS AND/OR CHANGES REGARDING THE CONSTRUCTION INITIATION DATE.

**DOMINION EAST OHIO REQUIREMENTS**

IT IS THE CONTRACTOR'S RESPONSIBILITY TO MAINTAIN THE LATERAL AND SUBJACENT SUPPORT OF DOMINION ENERGY'S PIPELINE(S), IN COMPLIANCE TO 29 CFR, PART 1926, SUBPART P (SAFE EXCAVATION & SHORING). ONE-FOOT MINIMUM VERTICAL AND HORIZONTAL CLEARANCE MUST BE MAINTAINED BETWEEN DOMINION ENERGY OHIO'S (DEO) EXISTING PIPELINE(S) AND ALL OTHER IMPROVEMENTS. EXTREME CARE SHOULD BE TAKEN NOT TO HARM ANY DEO FACILITY (PIPELINES, ETC.) OR APPURTENANCE (PIPE COATING, TRACER WIRE, CATHODIC PROTECTION TEST STATION WIRES & DEVICES, VALVE BOXES, ETC.). DEO FACILITIES MUST BE PROTECTED WITH A TARP DURING BRIDGE CONSTRUCTION. THE CONTRACTOR WILL BE RESPONSIBLE AND LIABLE FOR ENSURING THAT ALL DEO EXISTING FACILITIES, ABOVE AND BELOW GROUND, REMAIN UNDAMAGED, ACCESSIBLE AND IN WORKING ORDER. THE CROSSING OF DEO'S PIPELINE WITH ANOTHER STEEL FACILITY MAY CREATE A POTENTIAL CORROSION ISSUE FOR THE PROPOSED FACILITY AND THE EXISTING DEO FACILITY. PLEASE CONTACT DOMINION ENERGY OHIO'S CORROSION DEPARTMENT: DAVE CUTLIP (330-266-2121), RICK MCDONALD (330-266-2122), OR AL HUMRICHOUSER (330-478-3757).

**CONSTRUCTION NOISE**

ACTIVITIES AND LAND USE ADJACENT TO THIS PROJECT MAY BE AFFECTED BY CONSTRUCTION NOISE. IN ORDER TO MINIMIZE ANY ADVERSE CONSTRUCTION NOISE IMPACTS, DO NOT OPERATE POWER-OPERATED CONSTRUCTION-TYPE DEVICES BETWEEN THE HOURS OF 8:00 PM AND 7:00 AM. IN ADDITION, DO NOT OPERATE AT ANY TIME ANY DEVICE IN SUCH A MANNER THAT THE NOISE CREATED SUBSTANTIALLY EXCEEDS THE NOISE CUSTOMARILY AND NECESSARILY ATTENDANT TO THE REASONABLE AND EFFICIENT PERFORMANCE OF SUCH EQUIPMENT.

**ITEM 619 - FIELD OFFICE, TYPE B, AS PER PLAN**

A TYPE B FIELD OFFICE IS REQUIRED FOR THIS PROJECT. THE FOLLOWING REVISIONS TO EQUIPMENT SUPPLIED WITH THE TYPE B FIELD OFFICE, AS SPECIFIED IN TABLE 619.02-1, FIELD OFFICE, SHALL APPLY:

- THE BROADBAND INTERNET CONNECTION MUST MEET A MINIMUM UPLOAD SPEED OF 5MB PER SECOND.
- CONTRACTOR SHALL FURNISH AND SET UP A WI-FI ROUTER MEETING THE REQUIREMENTS OF IEEE 802.11AC FOR THE EXCLUSIVE USE OF THE DEPARTMENT.

ALL OTHER FIELD OFFICE ITEMS SUPPLIED SHALL MEET THE REQUIREMENTS OF A TYPE B, FIELD OFFICE.

ITEM 619 - FIELD OFFICE, TYPE B, AS PER PLAN 8 MONTHS

PRIMARY PROJECT CONTROL INFORMATION						
CONTROL POINT NUMBER	CL R/W & CONST.		PROJECT GRID		ORTHOMETRIC HEIGHT ELEVATION	DESCRIPTION
	STATION	OFFSET	NORTHING	EASTING		
1	146+93.48	-27.86	656455.8122	2286711.1042	1086.121	CTRL IP
2	144+56.87	53.20	656368.3594	2286476.7894	1093.574	CTRL IP
3	143+53.64	-381.22	656800.4648	2286365.3764	1083.258	CTRL IP

CALCULATED: KJA  
 CHECKED: ACB  
**GENERAL NOTES**  
 GEA -87 -2.73  
 2  
 20

L:\ODOT\19068303-00\_VAR-D12-D03-SftyDsgn\02\_GEA-87\110882\_Roadway\Sheets\110882\_GN001.dgn 9/15/2020 2:52:37 PM ghonsel

**PROTECTION OF RIGHT-OF-WAY LANDSCAPING**

PRIOR TO BEGINNING WORK, THE CONTRACTOR, THE PROJECT ENGINEER, AND A REPRESENTATIVE OF THE MAINTAINING AGENCY WILL REVIEW AND RECORD ALL LANDSCAPING ITEMS WITHIN THE RIGHT-OF-WAY (BOTH WITHIN AND OUTSIDE THE CONSTRUCTION LIMITS). A RECORD OF THIS REVIEW WILL BE KEPT IN THE PROJECT ENGINEER'S FILES. PRIOR TO FINAL ACCEPTANCE, A FINAL REVIEW OF LANDSCAPING ITEMS WILL BE MADE.

CONSTRUCT ALL ACTIVITIES, EQUIPMENT STORAGE, AND STAGING TO WITHIN THE CONSTRUCTION LIMITS. UNLESS OTHERWISE IDENTIFIED IN THE PLANS OR PROPOSAL, THE CONSTRUCTION LIMITS ARE IDENTIFIED AS 30 FEET FROM THE EDGE OF PAVEMENT.

SUBMIT A WRITTEN REQUEST TO THE PROJECT ENGINEER TO USE ANY AREA OUTSIDE THESE LIMITS. THE DOCUMENT SUBMITTED MUST CLEARLY IDENTIFY THE AREA AND EXPLAIN THE PROPOSED USE AND RESTORATION OF THE AREA. USE OF THESE AREAS FOR DISPOSAL OF WASTE MATERIAL AND CONSTRUCTION DEBRIS, EXCAVATION OF BORROW MATERIAL AND PLACEMENT OF PORTABLE PLANTS IS PROHIBITED. THE REQUEST MUST BE APPROVED, IN WRITING, BEFORE THE CONTRACTOR HAS PERMISSION TO USE THE AREA.

ANY ITEMS DAMAGED BEYOND THE CONSTRUCTION LIMITS, AS DEFINED ABOVE, WILL BE REPLACED IN KIND OR AS APPROVED BY THE PROJECT ENGINEER.

**ITEM 614 MAINTENANCE OF TRAFFIC SIGNAL/FLASHER INSTALLATION**

THE CONTRACTOR SHALL BE RESPONSIBLE FOR MAINTAINING TRAFFIC SIGNAL/FLASHER INSTALLATIONS WITHIN THE PROJECT UNDER THE FOLLOWING CONDITIONS:

1. EXISTING SIGNAL/FLASHER INSTALLATIONS WHICH THE PLANS REQUIRE THE CONTRACTOR TO ADJUST, MODIFY, ADD ONTO OR REMOVE, OR WHICH THE CONTRACTOR ACTUALLY ADJUSTS, MODIFIES OR OTHERWISE DISTURBS. THE CONTRACTOR SHALL BE RESPONSIBLE FOR THE ENTIRE INSTALLATION (AT AN INTERSECTION) FROM THE TIME HIS OPERATIONS FIRST DISTURB THE INSTALLATION UNTIL THE INSTALLATION HAS BEEN SUBSEQUENTLY REMOVED OR MODIFIED AND THE WORK ACCEPTED.
2. NEW OR REUSED SIGNAL/FLASHER INSTALLATIONS OR DEVICES INSTALLED BY THE CONTRACTOR. THE CONTRACTOR SHALL BE RESPONSIBLE FOR MAINTENANCE OF THESE FROM THE TIME OF INSTALLATION UNTIL THE WORK IS ACCEPTED.

THE CONTRACTOR SHALL CORRECT AS QUICKLY AS POSSIBLE ALL OUTAGES OR MALFUNCTIONS. HE SHALL PROVIDE THE MAINTAINING AGENCY AND THE ENGINEER SUCH ADDRESSES AND PHONE NUMBERS WHERE HIS MAINTENANCE FORCES CAN BE CONTACTED. THE CONTRACTOR SHALL PROVIDE ONE OR MORE PERSONS TO RECEIVE ALL CALLS AND DISPATCH THE NECESSARY MAINTENANCE FORCES TO CORRECT OUTAGES. SUCH A PERSON OR PERSONS MAY BE USED TO PERFORM OTHER DUTIES AS LONG AS PROMPT ATTENTION IS GIVEN TO THESE CALLS AND A PERSON IS READILY AVAILABLE CONTINUOUSLY 24 HOURS A DAY, 7 DAYS A WEEK. ALL LAMP OUTAGES, CABLE OUTAGES, ELECTRICAL FAILURES, EQUIPMENT MALFUNCTIONS AND MISALIGNED SIGNAL HEADS SHALL BE CORRECTED TO THE SATISFACTION OF THE ENGINEER WITH THE SIGNAL BACK TO SERVICE WITHIN FOUR HOURS AFTER THE CONTRACTOR HAS BEEN NOTIFIED OF THE OUTAGE.

IN THE EVENT NEW SIGNALS ARE DAMAGED PRIOR TO ACCEPTANCE, ALL DAMAGED EQUIPMENT EXCEPT POLES AND CONTROL EQUIPMENT SHALL BE REPLACED BY THE CONTRACTOR TO THE SATISFACTION OF THE ENGINEER WITH THE SIGNAL BACK IN SERVICE WITHIN 8 HOURS AFTER THE CONTRACTOR'S NOTIFICATION OF THE OUTAGE. THE CONTRACTOR SHALL ARRANGE FOR FULL TRAFFIC CONTROL UNTIL THE SIGNAL IS BACK IN OPERATION.

IF POLES AND/OR CONTROL EQUIPMENT ARE DAMAGED AND MUST BE REPLACED, THE CONTRACTOR SHALL MAKE TEMPORARY REPAIRS AS NECESSARY TO BRING THE SIGNAL BACK INTO FULL OPERATION WITHIN THE ALLOWED 8-HOUR PERIOD, AND SHALL MAKE PERMANENT REPAIRS OR REPLACEMENT AS SOON THEREAFTER AS POSSIBLE.

NONE OF THE ABOVE SHALL BE CONSTRUED AS COLLECTIVE OR CONSECUTIVE OUTAGE TIME PERIODS AT ANY ONE LOCATION. THAT IS, WHERE MORE THAN ONE OUTAGE OCCURS AT ANY ONE LOCATION THEN THE ALLOTTED TIME LIMIT SHALL BE FOR THE WORST SINGLE OUTAGE.

WHERE OUTAGES ARE THE DIRECT RESULT OF A VEHICLE ACCIDENT, THE RESPONSE OF THE CONTRACTOR SHALL BE AS

OUTLINED ABOVE. THE CONTRACTOR SHALL BE RESPONSIBLE FOR COLLECTION OF ANY COMPENSATION FOR THIS WORK FROM THOSE PARTIES RESPONSIBLE FOR THE DAMAGE.

WHERE THE CONTRACTOR HAS FAILED TO, OR CANNOT RESPOND TO, AN OUTAGE OR SIGNAL EQUIPMENT MALFUNCTION, AT THESE LOCATIONS WITHIN HIS RESPONSIBILITY, WITHIN PERIODS AS SPECIFIED ABOVE, THE ENGINEER MAY INVOKE THE PROVISIONS OF SECTION 105.15 AND ANY SUBSEQUENT BILLINGS TO THE STATE OR THE COUNTY FOR POLICE SERVICES AND MAINTENANCE SERVICES BY STATE/COUNTY FORCES SHALL BE DEDUCTED FROM MONIES DUE OR TO BECOME DUE THE CONTRACTOR IN ACCORDANCE WITH PROVISIONS OF SECTION 105.15.

THE CONTRACTOR SHALL PROVIDE THE MAINTENANCE SERVICE ENTIRELY WITH HIS FORCES OR HE MAY CHOOSE TO ENTER INTO A COOPERATIVE UNDERSTANDING WITH THE LOCAL MAINTAINING AGENCY TO PROVIDE THE MAINTENANCE. THE CONTRACTOR SHALL INFORM THE ENGINEER, IN WRITING, OF THE MAINTENANCE METHOD SELECTED.

THE CONTRACTOR SHALL BE RESPONSIBLE FOR ANY DAMAGE TO ANY TRAFFIC SIGNAL COMPONENTS REQUIRED TO BE HANDLED DURING THE RELOCATION OF POLES AND REVISIONS TO THE SIGNAL SYSTEM.

WHEN A TRAFFIC SIGNAL MUST BE TAKEN OUT OF SERVICE BY THE CONTRACTOR, DUE TO CONSTRUCTION PROCEDURES, THIS OUTAGE SHALL NOT EXCEED 4 HOURS AND SHALL NOT INCLUDE THE HOURS OF 7 AM TO 9 AM OR 4 PM TO 6 PM. ANY SIGNALIZED INTERSECTION, WHERE THE SIGNAL IS OUT OF SERVICE DUE TO CONSTRUCTION PROCEDURES, OR DUE TO AN OUTAGE OR MALFUNCTION OF EQUIPMENT AS DESCRIBED ABOVE, SHALL BE PROTECTED, BY THE CONTRACTOR, BY THE INSTALLATION OF TEMPORARY "STOP" SIGNS.

ANY VEHICULAR TRAFFIC SIGNAL HEAD, EITHER NEW OR EXISTING WHICH WILL BE OUT OF OPERATION SHALL BE COVERED IN THE MANNER DESCRIBED IN 632.25.

- THE CONTRACTOR SHALL MAINTAIN COMPLETE RECORDS OF MALFUNCTIONS INCLUDING:
1. TIME OF NOTIFICATION OF MALFUNCTION;
  2. TIME OF WORK CREWS ARRIVAL TO CORRECT THE MALFUNCTION;
  3. ACTIONS TAKEN TO CORRECT THE MALFUNCTION, INCLUDING A LIST OF PARTS REPAIRED OR REPLACED;
  4. A DIAGNOSIS OF REASON FOR THE MALFUNCTION AND PROBABILITY OF RE-OCCURRENCE;
  5. TIME OF COMPLETION OF THE REPAIR AND SYSTEM RESTORED TO FULL SERVICE.

A COPY OF THESE RECORDS SHALL BE PROVIDED TO THE ENGINEER WITHIN THREE (3) WORKING DAYS FOLLOWING COMPLETION OF EACH REPAIR.

A MINIMUM OF ONE LANE OF TRAFFIC IN EACH DIRECTION SHALL BE MAINTAINED AT ALL TIMES BY USE OF THE EXISTING PAVEMENT.

ALL COSTS RESULTING FROM THE ABOVE REQUIREMENTS SHALL BE CONSIDERED TO BE INCLUDED IN THE LUMP SUM PRICE BID FOR ITEM 614, MAINTAINING TRAFFIC.

**ITEM 614, LAW ENFORCEMENT OFFICER (WITH PATROL CAR) FOR ASSISTANCE DURING CONSTRUCTION OPERATIONS**

USE OF LAW ENFORCEMENT OFFICERS (LEOS) BY CONTRACTORS OTHER THAN THE USES SPECIFIED BELOW WILL NOT BE PERMITTED AT PROJECT COST. LEOS SHOULD NOT BE USED WHERE THE OMTCD INTENDS THAT FLAGGERS BE USED.

IN ADDITION TO THE REQUIREMENTS OF C&MS 614 AND THE OMTCD, A UNIFORMED LEO WITH AN OFFICIAL PATROL CAR (CAR WITH TOP-MOUNTED EMERGENCY FLASHING LIGHTS AND COMPLETE MARKINGS OF THE APPROPRIATE LAW ENFORCEMENT AGENCY) SHALL BE PROVIDED FOR THE FOLLOWING TRAFFIC CONTROL TASKS:

DURING THE ENTIRE ADVANCE PREPARATION AND CLOSURE SEQUENCE WHERE COMPLETE BLOCKAGE OF TRAFFIC IS REQUIRED.

DURING A TRAFFIC SIGNAL INSTALLATION WHEN IMPACTING THE NORMAL FUNCTION OF THE SIGNAL OR THE FLOW OF TRAFFIC, OR WHEN TRAFFIC NEEDS TO BE DIRECTED THROUGH AN ENERGIZED TRAFFIC SIGNAL CONTRARY TO THE SIGNAL DISPLAY (E.G., DIRECTING MOTORISTS THROUGH A RED LIGHT).

IN ADDITION TO THE REQUIREMENT OF C&MS 614 AND THE

OMUTCD, A UNIFORMED LEO WITH AN OFFICIAL PATROL CAR (CAR WITH TOP-MOUNTED EMERGENCY FLASHING LIGHTS AND COMPLETE MARKINGS OF THE APPROPRIATE LAW ENFORCEMENT AGENCY) SHOULD BE PROVIDED FOR THE FOLLOWING TRAFFIC CONTROL TASKS AS APPROVED BY THE ENGINEER:

FOR LANE CLOSURES: DURING INITIAL SET-UP PERIODS, TEAR DOWN PERIODS, SUBSTANTIAL SHIFTS OF A CLOSURE POINT OR WHEN NEW LANE CLOSURE ARRANGEMENTS ARE INITIATED FOR LONG-TERM LANE CLOSURES/SHIFTS (FOR THE FIRST AND LAST DAY OF MAJOR CHANGES IN TRAFFIC CONTROL SETUP).

IN GENERAL, LEOS SHOULD BE POSITIONED IN ADVANCE OF AND ON THE SAME SIDE AS THE LANE RESTRICTION OR AT THE POINT OF ROAD CLOSURE, AND TO MANUALLY CONTROL TRAFFIC MOVEMENTS THROUGH SIGNALIZED INTERSECTIONS IN WORK ZONES.

LEOS SHOULD NOT FORGO THEIR TRAFFIC CONTROL RESPONSIBILITIES TO APPREHEND MOTORISTS FOR ROUTINE TRAFFIC VIOLATIONS. HOWEVER, IF A MOTORIST'S ACTIONS ARE CONSIDERED TO BE RECKLESS, THEN PURSUIT OF THE MOTORIST IS APPROPRIATE.

THE LEOS WORK AT THE DIRECTION OF THE CONTRACTOR. THE CONTRACTOR IS RESPONSIBLE FOR SECURING THE SERVICES OF THE LEOS WITH THE APPROPRIATE AGENCIES AND COMMUNICATING THE INTENTIONS OF THE PLANS WITH RESPECT TO DUTIES OF THE LEOS. THE ENGINEER SHALL HAVE FINAL CONTROL OVER THE LEOS' DUTIES AND PLACEMENT, AND WILL RESOLVE ANY ISSUES THAT MAY ARISE BETWEEN THE TWO PARTIES.

ENSURE PROVIDED LEOS HAVE BEEN TRAINED APPROPRIATE TO THE JOB DECISIONS THEY ARE REQUIRED TO MAKE WHILE ON THE PROJECT, IN ACCORDANCE WITH C&MS 614.03.

THE LEO SHALL REPORT IN TO THE CONTRACTOR PRIOR TO THE START OF THE SHIFT, IN ORDER TO RECEIVE INSTRUCTIONS REGARDING SPECIFIC WORK ASSIGNMENTS DURING HIS/HER SHIFT. THE LEO IS EXPECTED TO STAY AT THE PROJECT SITE FOR THE ENTIRE DURATION OF HIS/HER SHIFT. THE LEO SHALL REPORT TO THE CONTRACTOR AT THE END OF HIS/HER SHIFT. SHOULD IT BE NECESSARY TO LEAVE THE PROJECT SITE, THE LEO SHALL NOTIFY THE ENGINEER. THE CONTRACTOR SHALL PROVIDE THE LEO WITH A TWO-WAY COMMUNICATION DEVICE WHICH SHALL BE RETURNED TO THE CONTRACTOR AT THE END OF HIS/HER SHIFT.

LEOS (WITH PATROL CAR) REQUIRED BY THE TRAFFIC MAINTENANCE TASKS ABOVE SHALL BE PAID FOR ON A UNIT PRICE (HOURLY) BASIS UNDER ITEM 614, LAW ENFORCEMENT OFFICER (WITH PATROL CAR) FOR ASSISTANCE. THE FOLLOWING ESTIMATED QUANTITIES HAVE BEEN CARRIED TO THE GENERAL SUMMARY:  
 ITEM 614, LAW ENFORCEMENT OFFICER WITH PATROL CAR FOR ASSISTANCE 50 HOURS

THE HOURS PAID SHALL INCLUDE ANY MINIMUM SHOW-UP TIME REQUIRED BY THE LAW ENFORCEMENT AGENCY INVOLVED.

ANY ADDITIONAL COSTS (ADMINISTRATIVE OR OTHERWISE) INCURRED BY THE CONTRACTOR TO OBTAIN THE SERVICES OF A LEO ARE INCLUDED WITH THE BID UNIT PRICE FOR ITEM 614, LAW ENFORCEMENT OFFICER WITH PATROL CAR FOR ASSISTANCE.

**POWER SUPPLY FOR TRAFFIC SIGNALS**

ELECTRIC POWER SHALL BE OBTAINED FROM THE ILLUMINATING COMPANY, 6896 MILLER ROAD, SUITE 101, BRECKSVILLE, OHIO 44141, AT THE LOCATION INDICATED ON THE PLANS. POWER SUPPLIED SHALL BE 120 VOLTS

**SIGNAL ACTIVATION**

PRIOR TO ACTIVATING THE NEW TRAFFIC SIGNAL TO STOP AND GO MODE AND/OR REMOVING THE EXISTING TRAFFIC SIGNAL FROM SERVICE, ALL ITEMS IN THE PROPOSED SIGNAL PLAN SHALL BE FULLY COMPLETED, (I.E., VEHICLE DETECTION, PEDESTRIAN SIGNAL HEADS, ETC.). IF THERE ARE CONSTRUCTABILITY ISSUES (I.E., ROADWAY WIDENING, ETC.) THAT PREVENT THE SIGNAL FROM BEING COMPLETED PRIOR TO ACTIVATION, IT SHALL BE BROUGHT TO THE ATTENTION OF THE PROJECT ENGINEER FOR THE CITY. THE PROJECT ENGINEER WILL THEN REVIEW, APPROVE OR REJECT PROPOSALS TO ACTIVATE THE TRAFFIC SIGNAL PRIOR TO COMPLETION.

THE CONTRACTOR SHALL NOTIFY THE PROJECT ENGINEER AT LEAST 10 WORKING DAYS PRIOR TO SCHEDULING THE FINAL INSPECTION OF THE SIGNAL INSTALLATION. FINAL

INSPECTION IS NOT CONSIDERED COMPLETE UNTIL DESIGNATED TRAFFIC PERSONNEL INSPECT THE TRAFFIC SIGNAL AND ISSUE WRITTEN APPROVAL. IF ISSUES ARE FOUND DURING THE FINAL INSPECTION THAT EFFECT THE SAFETY OF THE TRAVELING PUBLIC AND/OR THE EFFICIENCY OF THE INTERSECTION, THE SIGNAL SHALL NOT BE ACTIVATED ON THE PROPOSED DATE. ANY PUNCH LIST ITEMS THAT ARE FOUND SHALL BE CORRECTED AND REINSPECTED BY THE ENGINEER PRIOR TO FINAL ACCEPTANCE. CITY FORCES SHALL ONLY ASSUME DAY TO DAY MAINTENANCE OF THE TRAFFIC SIGNAL AFTER FINAL WRITTEN ACCEPTANCE HAS BEEN ISSUED.

**DETECTION MAINTENANCE**

IF VEHICLE DETECTION BECOMES UNEXPECTEDLY DISABLED, REQUIRES MODIFICATION, OR IS SCHEDULED TO BE TEMPORARILY REMOVED DURING THE CONSTRUCTION PROJECT, THE CONTRACTOR SHALL IMMEDIATELY NOTIFY THE PROJECT ENGINEER AND DISTRICT TRAFFIC ENGINEER.

IF THE LOSS OF VEHICLE DETECTION IS KNOWN PRIOR TO THE START OF CONSTRUCTION, IT SHALL BE DISCUSSED AT THE PRECONSTRUCTION MEETING. AT SUCH TIME, THE DISTRICT TRAFFIC ENGINEER SHALL ADVISE THE PROJECT ENGINEER AND CONTRACTOR ON THE APPROPRIATE ACTION TO RECTIFY ANY LOSS OF VEHICLE DETECTION. THIS MAY INCLUDE PLACING THE TRAFFIC SIGNAL ON MINIMUM OR MAXIMUM RECALL, MODIFYING THE MINIMUM GREEN TIMES, AND REMOVING THE MALFUNCTIONING DETECTION FROM SERVICE. WHERE NONINTRUSIVE DETECTION (I.E. VIDEO, RADAR) ALREADY EXISTS, THE CONTRACTOR SHALL INSURE THAT DETECTION IS OPERATING AND MAINTAINED BY RECONFIGURING THE DETECTION UNITS ACCORDINGLY DURING ALL CONSTRUCTION PHASES. THIS IS TO AVOID THE SIGNAL FROM MAXING OUT THE EFFECTED SIGNAL PHASE AND CREATING UNNECESSARY DELAYS.

LOCATIONS WHERE NON-INTRUSIVE DETECTION IS PROPOSED AND THE EXISTING VEHICLE DETECTION IS TO BE ABANDONED, THE NON-INTRUSIVE VEHICLE DETECTION SHALL BE INSTALLED, CONFIGURED AND MADE FULLY FUNCTIONAL PRIOR TO THE EXISTING DETECTION BEING DISABLED. THE CONTRACTOR SHALL CONTINUE TO MAINTAIN AND MODIFY THE DETECTION UNTIL FINAL ACCEPTANCE OF THE TRAFFIC SIGNAL. THIS IS TO ENSURE VEHICLE DETECTION REMAINS FULLY FUNCTIONAL THROUGHOUT CONSTRUCTION.

**WORK INSPECTION**

THE CONTRACTOR SHALL PROVIDE THE PROJECT ENGINEER WITH 72 HOUR NOTICE OF ANY SIGNAL WORK TO BE PERFORMED AT THE INTERSECTION SITE(S) SO THAT INSPECTION SERVICES CAN BE SUPPLIED.

**ITEM 630 SIGN HANGER ASSEMBLY, MAST ARM, AS PER PLAN**

IN ADDITION TO ITEM 630, SIGNS SHALL RIGIDLY ATTACHED TO THE MAST ARM INSTEAD OF BEING SUSPENDED FROM THE MAST ARM. THE SIGN SUPPORT ASSEMBLY SHALL COMPLY WITH ITEM 630.06 AND BE FULLY ADJUSTABLE TO ENABLE ORIENTATION OF SIGN FACES PERPENDICULAR TO THE APPROACH LANES. THIS ITEM SHALL INCLUDE ALL NECESSARY HARDWARE FASTENERS THAT ARE CORROSION RESISTANT, AND ACCESSORIES.

PAYMENT SHALL BE MADE AT THE CONTRACT UNIT PRICE BID PER EACH OF ITEM 630 SIGN HANGER ASSEMBLY, MAST ARM, AS PER PLAN IN PLACE.

**ITEM 630 SIGN SUPPORT ASSEMBLY, POLE MOUNTED, AS PER PLAN**

THE CONTRACTOR SHALL ATTACH A STAINLESS STEEL SIGN SUPPORT TO THE VERTICAL SIGNAL SUPPORT. THE SIGN SUPPORT SHALL BE ATTACHED TO THE TOP AND BOTTOM OF A SIGN BLANK AND BANDED TO A STRAIN POLE HAVING A DIAMETER BETWEEN 2 AND 14 INCHES THEREBY SECURING THE SIGN IN A CANTILEVERED POSITION. THIS ITEM SHALL INCLUDE ALL NECESSARY HARDWARE, FASTENERS, AND ACCESSORIES. THE SIGN SUPPORT SHALL BE MOUNTED AT A MINIMUM HEIGHT OF 14 FEET. THE ENGINEER SHALL INSPECT AND APPROVE THE FINAL LOCATION OF THE STREET NAME SIGN SUPPORT PRIOR TO INSTALLATION.

PAYMENT SHALL BE MADE AT THE CONTRACT UNIT PRICE BID, PER EACH OF CMS ITEM 630 SIGN SUPPORT ASSEMBLY, POLE MOUNTED, AS PER PLAN.

L:\ODOT\19068303-00\_VAR-D12-D03-SftyDsgn\02\_GEA-87\110882\Roadway\Sheets\110882\_SN001.dgn 9/15/2020 2:52:38 PM ghonsel

L:\ODOT\19068303-00\_VAR-D12-D03-SftyDsgn\02\_GEA-87\110882\Roadway\Sheets\110882\_SN001.dgn 9/15/2020 2:52:39 PM ghonsel

**ITEM 632 REMOVAL OF TRAFFIC SIGNAL INSTALLATION**

TRAFFIC SIGNAL INSTALLATIONS, INCLUDING SIGNAL HEADS, CABLE, MESSENGER WIRE, STRAIN POLES, CABINET, CONTROLLER, ETC., SHALL BE REMOVED IN ACCORDANCE WITH CMS 632.26 AND AS INDICATED ON THE PLANS. REMOVED ITEMS SHALL BE DISPOSED OF IN ACCORDANCE WITH THE LISTING GIVEN HEREIN.

ITEMS TO BE DISPOSED:  
SIGNAL SUPPORTS (2)  
PEDESTAL (2)  
VEHICULAR SIGNAL HEAD (8)  
PEDESTRIAN SIGNAL HEAD (6)  
POLE MOUNTED CONTROLLER AND CABINET (1)  
PEDESTRIAN PUSH BUTTON (2)

THE CONTRACTOR SHALL ALSO REMOVE ALL EXISTING FOUNDATIONS OF STRAIN POLES AND PEDESTALS TO A MINIMUM OF 1 FOOT BELOW GRADE AND REGRADE/RESOD THE AREA. EXISTING PULLBOXES SHALL ALSO BE REMOVED FOR DISPOSAL AND REGRADED IN A SIMILAR MANNER.

**ITEM 632 SIGNAL SUPPORT, TYPE TC-81.22, (BY DESIGN), AS PER PLAN**

IN ADDITION TO PROVISIONS OF THE ODOT C&MS, FURNISH AND INSTALL SIGNAL POLES AS SPECIFIED IN THE PLANS.

THE SIGNAL SUPPORT DESIGNER SHALL PROVIDE DRAWINGS OF A SIGNAL SUPPORT WITH STRUCTURAL ASPECTS OF THE DESIGN AND MATERIALS IN COMPLIANCE WITH THE AASHTO LRFDLTS-1.

SIGNAL SUPPORTS SHALL BE GALVANIZED PER 711.02. SUBMIT, TO THE ENGINEER PRIOR TO INCORPORATION: TWO COPIES OF THE SIGNAL SUPPORT DRAWINGS AND SHOP DRAWINGS, WHICH IDENTIFY AND DESCRIBE EACH MANUFACTURED SIGNAL SUPPORT AND SIGNAL SUPPORT ITEM WHICH IS BEING INCORPORATED INTO THE CONSTRUCTION. THE SIGNAL SUPPORT DRAWINGS AND SHOP DRAWINGS SHALL EACH BE REVIEWED, SEALED, STAMPED, AND DATED BY TWO OHIO REGISTERED PROFESSIONAL ENGINEERS.

TWO 3" CONDUIT ELLS SHALL BE FURNISHED IN THE FOUNDATION IN ACCORDANCE WITH THE TRAFFIC SIGNAL PLAN.

THE SIGNAL SUPPORT ON THE NORTHWEST QUADRANT SHALL HAVE A 2" WEATHERHEAD INSTALLED ABOVE THE HORIZONTAL MAST ARM TO PROVIDE A RACEWAY FROM THE OVERHEAD SERVICE CABLE TO THE DISCONNECT SWITCH (POLE MOUNTED). POWER CABLE TO THE CABINET WILL BE PAID USING A SEPARATE ITEM.

PAYMENT FOR ITEM 632 SIGNAL SUPPORT, TYPE TC-81.22, (BY DESIGN), AS PER PLAN SHALL BE MADE AT THE CONTRACT UNIT PRICE PER EACH COMPLETE AND IN PLACE, AND SHALL INCLUDE ALL SIGNAL SUPPORT DESIGN, LABOR, MATERIALS, AND EQUIPMENT NECESSARY TO COMPLETE THE WORK.

**SIGNAL SUPPORT FOUNDATION ELEVATIONS**

ELEVATIONS SHOWN IN THE PLANS FOR SIGNAL SUPPORT FOUNDATIONS ARE FOR COMPUTATIONAL PURPOSES ONLY. THE ACTUAL ELEVATION OF THE FOUNDATION SHALL BE IN ACCORDANCE WITH TRAFFIC SCD TC-21.21 PROVIDED THE EXISTING SLOPE IS LESS THAN 6:1.

AT LOCATIONS WHERE THE EXISTING SLOPE IS 6:1 OR GREATER, THE BURIED DEPTH OF FOUNDATION, AS SHOWN IN SCD TC-21.21 SHALL APPLY TO THE LOW SIDE OF THE SLOPE. THE TOP OF THE FOUNDATION SHALL BE SET 2 INCHES ABOVE THE EXISTING SURFACE ON THE HIGH SIDE OF THE SLOPE UNLESS OTHERWISE DIRECTED. THE ADDITIONAL DEPTH OF FOUNDATION NECESSARY TO MEET THESE REQUIREMENTS SHALL BE ADDED TO THE FORMED TOP.

**SIGNAL SUPPORT FOUNDATION**

PRIOR TO ORDERING THE SIGNAL SUPPORTS, THE CONTRACTOR SHALL CONTACT OUPS TO HAVE ALL THE UTILITIES LOCATED IN THE FIELD, THEN MEET WITH THE PROJECT ENGINEER TO LOCATE THE PROPOSED SUPPORT LOCATIONS TO INSURE THERE ARE NO CONFLICTS WITH UTILITIES. THE CONTRACTOR SHALL THEN POTHOLE THE LOCATIONS OF THE FOUNDATIONS TO VERIFY THERE ARE NO CONFLICTS PRIOR TO ORDERING THE POLES. IF THERE ARE ISSUES, PROJECT ENGINEER SHALL PROVIDE GUIDANCE AS TO THE RELOCATION OF THE SUPPORT POLES.

PAYMENT WILL BE MADE AT THE CONTRACT UNIT PRICE AND WILL BE FULL COMPENSATION FOR ALL LABOR, MATERIALS, TOOLS, EQUIPMENT AND OTHER INCIDENTALS NECESSARY FOR EACH SUPPORT FURNISHED, IN PLACE, COMPLETE AND ACCEPTED.

**ITEM 632 PEDESTRIAN SIGNAL HEAD (LED), COUNTDOWN, TYPE D2, AS PER PLAN**

IN ADDITION TO THE REQUIREMENTS OF C&MS 632 AND 732 THE FOLLOWING SHALL APPLY:  
1. SIGNAL HEADS AND VISORS SHALL BE CONSTRUCTED OF BLACK POLYCARBONATE PLASTIC AND MEET ITE SPECIFICATIONS.  
2. PROPER EXTERIOR COLORS SHALL BE OBTAINED BY USE OF COLORED PLASTIC MATERIAL RATHER THAN PAINTING.  
3. PIPE, SPACERS AND FITTINGS CONSTRUCTED OF POLYCARBONATE PLASTIC MAY BE USED IN LIEU OF GALVANIZED STEEL OR ALUMINUM.  
4. THE PEDESTRIAN SIGNAL HEAD SHALL BE OF THE LED COUNTDOWN TYPE.  
5. NEW ATTACHMENT HARDWARE AND FITTINGS SHALL BE USED  
6. THE LIGHT EMITTING DIODE (LED) MODULES SHALL MEET THE REQUIREMENTS OF C&MS 732.04-C.

THE CONTRACTOR SHALL PROVIDE ODOT DISTRICT 12, IN WRITING, WITH THE LED MANUFACTURER NAME, SERIAL NUMBER, PART NUMBER, DESCRIPTION OF LAMP, AND DATE OF MANUFACTURE FOR ALL LED UNITS THAT ARE TO BE USED IN THE SIGNAL HEAD PRIOR TO INSTALLATION, FOR ACCEPTANCE AND WARRANTY PURPOSES.

PAYMENT FOR ITEM 632 PEDESTRIAN SIGNAL HEAD (LED), COUNTDOWN, TYPE D2, AS PER PLAN SHALL BE MADE FOR THE NUMBER OF COMPLETE SIGNAL HEAD FURNISHED AND INSTALLED, INCLUDING ALL LABOR, EQUIPMENT, MATERIALS AND NEW ATTACHMENT HARDWARE.

**ITEM 633 CONTROLLER WORK PAD, AS PER PLAN**

THIS ITEM SHALL ADHERE TO ALL REQUIREMENTS OF ITEM 633 CONTROLLER WORK PAD WITH THE FOLLOWING EXCEPTIONS:

CONTROLLER WORK PAD SHALL BE EXTENDED TO SUPPORT A PROPOSED UNINTERRUPTIBLE POWER SUPPLY (UPS).

PAYMENT FOR SHALL BE MADE AT THE CONTRACT UNIT PRICE BID PER EACH OF ITEM 633 CONTROLLER WORK PAD, AS PER PLAN, COMPLETE.

**ITEM 633 CABINET, TYPE 332L, AS PER PLAN**

THE CABINET SHALL BE FURNISHED AND INSTALLED ACCORDING TO C&MS 633 AND 733 AND BE LISTED ON THE TRAFFIC AUTHORIZED PRODUCTS LIST (TAP).

THE CABINET SHALL BE FURNISHED WITH AN EDI MONITOR AS ALLOWED ON THE TAP/APPROVED PRODUCTS LIST.

THE CONTRACTOR SHALL NOT REASSIGN THE CABINET DETECTOR INPUTS IN ORDER TO REDUCE THE NUMBER OF 2-CHANNEL DETECTOR UNITS SUPPLIED AND SHALL USE THE STANDARD CALTRANS INPUT FILE DESIGNATIONS FOLLOWING PLAN IN SERT SHEET 203324.

PAYMENT FOR ITEM 633 CABINET, TYPE 332L, AS PER PLAN WILL BE AT THE CONTRACT BID PRICE PER EACH COMPLETE AND IN PLACE INCLUDING ALL CONNECTIONS TESTED AND ACCEPTED.

**ITEM 633 UNINTERRUPTIBLE POWER SUPPLY (UPS), 1000 WATT, AS PER PLAN**

IN ADDITION TO THE REQUIREMENTS OF C&MS 633 AND 733, A CABINET RISER (8 INCH MINIMUM) AND ANCHOR BOLTS WILL BE PROVIDED FOR BASE-MOUNTED CABINETS. BEFORE PERFORMING THE WORK, THE CONTRACTOR, THE DISTRICT TRAFFIC ENGINEER AND THE PROJECT ENGINEER WILL PERFORM A SITE INSPECTION TO ESTABLISH THE LOCATION OF THE UPS CABINET AND FOUNDATION.

THE UPS CABINET SHALL INCLUDE A GENERATOR POWER PANEL WITH A HEAVY DUTY POWER RELAY VERSUS THE LINE VOLTAGE GENERATOR SWITCH. THE GENERATOR INLET SHALL BE A RECESSED PANEL WITH A DOOR THAT IS FLUSH WITH THE EXTERNAL SIDE OF THE UPS CABINET. IT SHALL INCLUDE A RECESSED PLUG, AUTOMATIC TRANSFER SWITCH AND A DOOR THAT SECURELY CLOSES OVER THE POWER CORD.

THE UPS OUTPUT NOTIFICATIONS FOR ON BATTERY, BATTERY 2-HOUR TIMER, AND LOW BATTERY SHALL BE WIRED INTO THE TRAFFIC SIGNAL CABINET BACK PANEL TO PROVIDE SPECIAL STATUS ALARMS FOR EACH OUTPUT INTO THE SIGNAL CONTROLLER.

THIS ITEM SHALL INCLUDE A RED LED STATUS INDICATOR LAMP TO ALLOW MAINTENANCE PERSONNEL AND LAW ENFORCEMENT TO QUICKLY ASSESS WHETHER A TRAFFIC SIGNAL CABINET IS BEING POWERED BY A UPS. THE LED HOUSING SHALL BE NEMA 4X, IP65 OR IP66, RATED FOR OUTDOOR USE AND BE TAMPER/SHATTER RESISTANT. IT SHALL BE A DOMED ENCLOSURE CONTAINING A RED LENS WITH LED THAT IS VISIBLE FROM 100 FOOT MINIMUM. THE ENCLOSURE AND LED MODULE SHOULD BE PLACED AND CENTERED ON THE TOP SURFACE OF THE UPS CABINET AND SEALED FROM WATER INTRUSION. IT SHOULD BE WIRED USING MINIMUM 20GA STRANDED, INSULATED HOOKUP WIRE TO THE STATUS RELAY OUTPUTS OF THE UPS. THE WIRES SHALL BE TERMINATED BY LUGS AT THE DISPLAY END AND PERMANENTLY LABELED "BACKUP POWER STATUS DISPLAY," WITH WIRE POLARITY INDICATED. THE RED LED SHALL ONLY ILLUMINATE TO INDICATE THE CABINET IS OPERATING UNDER UPS BACKUP POWER (THE "BACKUP" OPERATING CONDITION). THIS ITEM INCLUDES PROGRAMMING THE UPS STATUS RELAY OUTPUTS TO PRODUCE THE LAMP STATUS DISPLAYS. THESE STATUS DISPLAYS WILL BE SOLID 100% DUTY CYCLE (NOT FLASHING) DISPLAYS. THE OPERATING VOLTAGE OF THE LED LAMP SHALL BE 120V AC UNLESS OTHERWISE INDICATED.

THIS ITEM SHALL ADHERE TO ALL REQUIREMENTS OF 633 UNINTERRUPTIBLE POWER SUPPLY (UPS), 1000 WATT WITH THE FOLLOWING EXCEPTIONS:

THE UNINTERRUPTIBLE POWER SUPPLY SHALL BE WIRED THROUGH THE CONTROLLER TO INTERFACE WITH THE CITY'S EXISTING CENTRACS CENTRAL SOFTWARE SYSTEM.

PROVIDE A RISER WITH EACH CABINET. CABINET RISERS PROVIDE AN EXTENSION OF THE CABINET BETWEEN THE GROUND MOUNTED CABINET AND THE FOUNDATION. BOLT THE RISER TO THE FOUNDATION, AND BOLT THE CABINET TO THE RISER. USE A TYPE (SIZE AND SHAPE) OF CABINET RISER COMPATIBLE WITH THE TYPE OF CONTROLLER CABINETS SPECIFIED FOR THE PROJECT.

SEAL THE JOINTS BETWEEN THE CONTROLLER CABINET AND CABINET RISER, AND BETWEEN THE CABINET RISER AND FOUNDATION WITH A QUALITY, CLEAR SILICONE CAULK.

PAYMENT SHALL BE MADE AT THE CONTRACT UNIT PRICE BID PER EACH OF ITEM 633 UNINTERRUPTIBLE POWER SUPPLY (UPS), 1000 WATT, AS PER PLAN.

**ITEM 633 COMMUNICATIONS, AS PER PLAN**

FURNISH A CELLULAR MODEM, ONE 3-ANTENNA ASSEMBLY (PART # 6001136), AND A 10' ETHERNET CABLE FOR REMOTE WIRELESS CELLULAR COMMUNICATION.

FOR NETWORK CONSISTENCY CELLULAR MODEMS SHALL BE THE SIERRA WIRELESS: MODEM, AIRLINK MP70 ETHERNET WITH AC TO DC POWER CABLE - MODEL 1102709KIT

THIS ITEM SHALL INCLUDE THE FURNISHING A MOUNTING BRACKET FOR THE ANTENNA WITH ALL NECESSARY HARDWARE INCLUDING BUT NOT LIMITED TO SPRING NUTS, WASHERS, AND BOLTS THAT INSTALLS TO THE MOUNTING CHANNEL ON THE SIDE OF THE SIGNAL CABINET.

THE CELLULAR MODEM EQUIPMENT SHALL BE DELIVERED TO ODOT DISTRICT 12 TRAFFIC FOR PROGRAMMING AND INSTALLATION.

ODOT DISTRICT 12 TRAFFIC  
ATTN: KEITH HAMILTON  
5500 TRANSPORTATION BOULEVARD  
GARFIELD HEIGHTS, OHIO 44125

THE CONTRACTOR SHALL PROVIDE THE MODEM SERIAL NUMBERS AND NECESSARY ESN NUMBERS FOR ODOT TO ESTABLISH WIRELESS SERVICE.

THE DEPARTMENT WILL MEASURE "COMMUNICATIONS, AS PER PLAN" BY THE NUMBER OF COMPLETE UNITS FURNISHED, RECEIVED, AND ACCEPTED BY ODOT DISTRICT 12 TRAFFIC.

**ITEM 809 EMERGENCY VEHICLE PREEMPTION**

THIS ITEM OF WORK SHALL CONSIST OF FURNISHING AND INSTALLING PREEMPTION EQUIPMENT IN THE LOCATIONS AND LOCAL CONTROLLERS AS SHOWN IN THE PLANS. THE PREEMPTION SHALL CONFORM TO ODOT SPECIFICATION 809 AND ASSOCIATED SUPPLEMENTAL SPECIFICATIONS AND SHALL UTILIZE COMMUNICATIONS TO IDENTIFY THE PRESENCE OF AN EMERGENCY PRIORITY VEHICLE. IT SHALL CAUSE THE TRAFFIC SIGNAL CONTROLLER TO SELECT A PRE-PROGRAMMED PREEMPTION PLAN THAT WILL DISPLAY AND HOLD THE DESIRED SIGNAL PHASE FOR THE DIRECTION OF THE EMERGENCY VEHICLE.

THE COMMUNICATIONS MEDIUM SHALL EMPLOY SOUND DETECTION TECHNIQUES TO DETERMINE AND LOG THE PRESENCE OF THE EMERGENCY VEHICLE. THE SYSTEM SHALL DETECT THE PRESENCE OF THE VEHICLE THROUGH AN EMITTING DEVICE LOCATED ON THE EMERGENCY VEHICLE. THE SYSTEM SHALL ACTIVATE THE PREEMPTION SEQUENCE BY APPLYING A SIGNAL TO ONE OF THE CONTROLLER'S PREEMPT DISCRETE INPUTS. THE SYSTEM SHALL BE COMPLETELY COMPATIBLE WITH THE CONTROLLER. ALL EQUIPMENT SHALL BE SONEM EQUIPMENT, LATEST EDITION.

THE EQUIPMENT SHALL BE SHELF OR RACK MOUNTED AND EASILY REMOVABLE AND REPLACEABLE WITHIN THE CABINET. THE EQUIPMENT SHALL BE SUPPLIED COMPLETELY WIRED IN THE CONTROLLER CABINET AND TESTED. THE SYSTEM SHALL BE CAPABLE OF PREEMPTING AND RECEIVING PRIORITY FOR EACH APPROACH TO THE INTERSECTION. IT SHALL BE POSSIBLE TO DETECT THE EMERGENCY VEHICLE AT LEAST 2000 FEET FROM THE INTERSECTION IN AN 80DB-A NOISE ENVIRONMENT.

ALL PREEMPTION PLANS SHOULD BE PROGRAMMED TO PREVENT THE YELLOW TRAP, UNLESS AS DIRECTED BY THE DISTRICT TRAFFIC ENGINEER. YELLOW TRAP PREVENT WILL FORCE THE TRANSITION THROUGH YELLOW CHANGE AND RED CLEARANCE FOR RESOLUTION OF YELLOW TRAP IF ANY PHASE OPPOSING THE PREEMPTION CLEARANCE PHASE(S) IS ACTIVE AND DISPLAYING A GREEN OR FLASHING YELLOW ARROW INDICATION WHEN THE PREEMPTION PLAN IS ACTIVATED AND THE PREEMPTION CLEARANCE PHASE(S) ARE GREEN.

SUPPLY EACH INTERSECTION SHOWN IN THE PLANS WITH THE FOLLOWING COMPONENTS, EACH BID SEPARATELY:  
1. ITEM 809 PREEMPTION RECEIVING UNIT  
2. ITEM 809 PREEMPTION DETECTOR CABLE  
3. ITEM 809 PREEMPTION PHASE SELECTOR  
4. ITEM 809 PREEMPTION CONFIRMATION LIGHT, LED

THE CONTRACTOR SHALL INVENTORY THE ABOVE EMERGENCY VEHICLES TO DETERMINE COMPATIBILITY OF THE SIRENS WITH THE SYSTEM. EACH VEHICLE THAT IS DETERMINED TO BE NOT COMPATIBLE SHALL BE SUPPLIED WITH NEW SIRENS AT COST INCIDENTAL TO THE SYSTEM.

THE CITY SHALL BE SUPPLIED WITH SOFTWARE REQUIRED TO CALIBRATE, LOG, AND OPERATE THE SYSTEM. TWO (2) OPERATING AND INSTRUCTION MANUALS SHALL BE SUPPLIED WITH THE SOFTWARE.

THE CONTRACTOR SHALL THOROUGHLY TEST THE INSTALLED SYSTEM. AS A MINIMUM, THE CONTRACTOR SHALL VERIFY THAT ALL CONNECTIONS ARE PROPERLY MADE TO THE CONTROLLER CABINETS. THE CONTROLLER SHALL CHECK THAT THE RANGE SETTING IS PROPER FOR EACH INTERSECTION. THE CONTROLLER SHALL DETERMINE THAT ALL PHASE SELECTORS ARE SELECTING THE PROPER PHASE AND TIMING ACCURATELY. THE CONTRACTOR SHALL VERIFY THAT ALL VEHICLE EMITTERS ARE BEING PROPERLY DETECTED.

PAYMENT FOR ITEM 809 EMERGENCY VEHICLE PREEMPTION SHALL BE MADE AT THE CONTRACT UNIT PRICE PER EACH PREEMPTION IN PLACE AND FULLY OPERATIONAL AS SHOWN IN THE PLANS, EXCEPT FOR THOSE ITEMS BID SEPARATELY.

**ITEM 809 PREEMPTION RECEIVING UNIT**

RECEIVING UNITS SHALL CONSIST OF A LIGHTWEIGHT, WEATHERPROOF AND DIRECTIONAL ASSEMBLY. EACH RECEIVING UNIT SHALL BE 360 DEGREE ADJUSTABLE. THE RECEIVING UNIT SHALL BE CAPABLE OF SENDING THE PROPER ELECTRICAL SIGNAL TO THE TRAFFIC SIGNAL CONTROLLER VIA THE PREEMPTION DETECTOR CABLE. RECEIVING UNITS SHALL BE SUPPLIED WITH MAST ARM MOUNTING HARDWARE AS SHOWN IN THE PLANS.

FURNISH PREEMPTION RECEIVING UNITS WITH 60-MONTH WARRANTIES OR FOR THE MANUFACTURER'S STANDARD WARRANTY WHICHEVER IS GREATER. ENSURE THAT THE WARRANTY PERIOD BEGINS ON THE DATE OF SHIPMENT TO THE PROJECT. ENSURE THAT EACH UNIT HAS A PERMANENT LABEL OR STAMP INDICATING THE DATE OF SHIPMENT.

PAYMENT FOR ITEM 809 PREEMPTION RECEIVING UNIT SHALL BE AT THE CONTRACT UNIT FOR EACH RECEIVING UNIT IN PLACE, COMPLETELY INSTALLED AT THE LOCATION SHOWN IN THE PLANS, WIRED, TESTED AND ACCEPTED.

**ITEM 809 PREEMPTION DETECTOR CABLE**

THIS ITEM SHALL CONSIST OF FURNISHING AND INSTALLING PREEMPTION DETECTOR HOME RUN CABLE IN THE LOCATIONS SHOWN IN THE PLANS. IT SHALL CONNECT THE PREEMPT RECEIVING UNITS TO THE PHASE SELECTORS IN THE LOCAL CONTROLLER CABINET.

PREEMPTION DETECTOR CABLE SHALL CONFORM TO ODOT SPECIFICATION 632. ONLY ONE EXTERNAL SPLICE SHALL BE PERMITTED BETWEEN PREEMPTION RECEIVER UNIT AND CONTROLLER CABINET. THIS SPLICE SHALL MEET THE REQUIREMENTS OF C&MS 632.23 USING A WATERPROOF EPOXY SPLICE KIT. THE CABLE SHALL BE APPROVED FOR BOTH OVERHEAD AND UNDERGROUND USE. THE JACKET SHALL WITHSTAND EXPOSURE TO SUNLIGHT AND ATMOSPHERIC TEMPERATURES AND STRESSES REASONABLY EXPECTED IN NORMAL INSTALLATIONS.

PAYMENT FOR ITEM 809 PREEMPTION DETECTOR CABLE SHALL BE MADE AT THE CONTRACT UNIT PRICE PER FOOT FOR THE CABLE FURNISHED, IN PLACE, ALL CONNECTIONS MADE AND WIRING COMPLETED, TESTED AND ACCEPTED.

**ITEM 809 PREEMPTION PHASE SELECTOR**

THIS ITEM SHALL CONSIST OF FURNISHING AND INSTALLING PREEMPT PHASE SELECTORS INCLUDING WIRING INTERFACE PANELS IN THE LOCAL CONTROLLER CABINET AND ALL OTHER ACCESSORIES THAT ARE NECESSARY TO MAKE THE PREEMPT PHASE SELECTORS COMPLETELY FUNCTIONAL AND OPERATIONAL AS SHOWN IN THE PLANS. THIS ITEM SHALL INCLUDE THE EXTRA CABINET SPACE NECESSARY TO BE LOCATED IN THE LOCAL CONTROLLER CABINETS WHERE INDICATED IN THE PLANS.

THE PHASE SELECTORS SHALL CONSIST OF A MODULE OR MODULES THAT WILL PROVIDE THE NECESSARY INPUTS TO THE CONTROLLER. PHASE SELECTORS SHALL BE SUPPLIED WITH SUFFICIENT QUANTITIES OF CHANNELS TO PROVIDE PREEMPTION FOR ALL APPROACHES TO THE INTERSECTION SEPARATELY. POWER SHALL BE OBTAINED FROM THE PHASE SELECTOR OR PHASE SELECTOR POWER SUPPLY AND NOT FROM THE LOCAL CONTROLLER TIMER.

THE PHASE SELECTORS SHALL HAVE FRONT PANEL INDICATORS FOR ACTIVE PREEMPT CHANNEL STATUS. IT SHALL HAVE TEST SWITCHES TO ACTIVATE ALL PREEMPT CHANNELS.

FURNISH PREEMPT PHASE SELECTORS WITH 60-MONTH WARRANTIES OR FOR THE MANUFACTURER'S STANDARD WARRANTY WHICHEVER IS GREATER. ENSURE THAT THE WARRANTY PERIOD BEGINS ON THE DATE OF SHIPMENT TO THE PROJECT. ENSURE THAT EACH UNIT HAS A PERMANENT LABEL OR STAMP INDICATING THE DATE OF SHIPMENT.

PAYMENT FOR ITEM 809 PREEMPT PHASE SELECTOR SHALL BE MADE AT THE CONTRACT UNIT PRICE FOR EACH PHASE SELECTOR IN PLACE, COMPLETELY INSTALLED IN THE LOCAL CONTROLLER SHOWN IN THE PLANS, WIRED, TESTED AND ACCEPTED.

**ITEM 809 PREEMPTION CONFIRMATION LIGHT, LED**

THIS ITEM SHALL CONSIST OF FURNISHING AND INSTALLING PREEMPT CONFIRMATION LIGHTS INCLUDING HARDWARE AND ALL OTHER ACCESSORIES THAT ARE NECESSARY TO MAKE THE PREEMPT CONFIRMATION LIGHT COMPLETELY FUNCTIONAL AND OPERATIONAL AS SHOWN IN THE PLANS.

A CONFIRMATION LIGHT SHALL BE SUPPLIED FOR EACH INTERSECTION TO INDICATE THAT THE EMERGENCY VEHICLE HAS ACHIEVED CONTROL OF THE TRAFFIC SIGNAL.

THE CONFIRMATION LIGHT SHALL BE A WEATHER TIGHT LIGHTING FIXTURE. IT SHALL BE SUPPLIED WITH A CLEAR GLOBE, LED LAMP AND MOUNTING HARDWARE TO ATTACH TO THE TRAFFIC SIGNAL MAST ARM. THE CONFIRMATION LIGHT SHALL BE POWERED BY A LOAD SWITCH IN THE TRAFFIC SIGNAL CONTROLLER. SIGNAL CABLE CONFORMING TO 732.19 SHALL BE USED FOR CONFIRMATION LIGHTS. A MINIMUM OF 4-CONDUCTOR CABLE SHALL BE USED WITH THE GREEN WIRE SERVING AS THE SAFETY GROUND CONDUCTOR. PAYMENT FOR ITEM 809 PREEMPT CONFIRMATION LIGHT, LED SHALL BE MADE AT THE CONTRACT UNIT PRICE FOR EACH LIGHT IN PLACE, COMPLETELY

INSTALLED IN THE LOCATION SHOWN IN THE PLANS, WIRED, TESTED AND ACCEPTED.

**ITEM 809 ATC V6.24 CONTROLLER, AS PER PLAN**

THE CONTROLLER UNIT SHALL BE FURNISHED AND INSTALLED PER SS809 AND BE LEISTED ON THE TRAFFIC AUTHORIZED PRODUCTS (TAP) LIST.

THE CONTROLLER SHALL BE AN ECONOLITE COBALT AND COMPATIBLE WITH THE CABINET TYPE BEING INSTALLED.

**ITEM 809 ADVANCE RADAR DETECTION, AS PER PLAN**

THIS ITEM OF WORK SHALL CONSIST OF FURNISHING AND INSTALLING A WAVETRONIX SMARTSENSOR ADVANCE DETECTION UNIT (MODEL SS-200E). THE DETECTION UNIT SHALL INCLUDE THE FOLLOWING:

1. POWER SHALL BE PROVIDED FROM THE TRAFFIC CABINET.
2. ALL REQUIRED INPUTS CARDS SHALL BE INCLUDED IN THE TRAFFIC CABINET AND SHALL BE COMPATIBLE WITH CALTRANS, NEMA TS1 AND NEMA TS2 DETECTOR RACKS. THE CARDS SHALL PROVIDE TRUE PRESENCE DETECTOR CALLS OR CONTACT CLOSURE TO THE TRAFFIC CONTROLLER.
3. THE UNIT SHALL BE MOUNTED DIRECTLY TO A POLE OR MAST ARM, AS RECOMMENDED BY THE MANUFACTURER. CABLE(S) SHALL BE PROVIDED AS REQUIRED AND RECOMMENDED BY THE MANUFACTURER.
4. SURGE PROTECTION DEVICES, AS RECOMMENDED BY THE MANUFACTURER SHALL BE INCLUDED BOTH AT THE POLE WHERE THE UNIT IS LOCATED TO PROTECT THE UNIT AND IN THE TRAFFIC CABINET TO PROTECT THE CABINET ELECTRONICS.
5. THE MANUFACTURER'S REPRESENTATIVE SHALL BE ON SITE DURING INSTALLATION AND TESTING AND SHALL PROVIDE ON-SITE TRAINING ON THE SETUP, OPERATION AND MAINTENANCE OF THE UNIT.
6. A SERIAL TO ETHERNET COMMUNICATIONS MODULE AND ETHERNET CABLE (MINIMUM 7 FEET).
7. THE POWER SUPPLY AND COMMUNICATION MODULES SHALL BE SECURED TO A SINGLE PANEL THAT CAN BE MOUNTED INTERIOR TO THE TRAFFIC CABINET. THE PANEL SHALL INCLUDE MODULAR-PLUG STYLE CONNECTIONS FOR UP TO FOUR (4) SENSOR CABLES. ADDITIONAL SENSORS MAY BE HARD-WIRED TO THE COMMUNICATION MODULES, AS NECESSARY.
8. THE CONTRACTOR SHALL INSTALL THE RADAR DETECTION PRIOR TO MILLING/DISABLING EXISTING LOOPS.
9. THE INSTALLATION SHALL INCLUDE ALL CONTROLLER PROGRAMMING FOR COMPLETE INSTALLATION, WHICH INCLUDES MODIFICATIONS FOR REMOVAL OF EXISTING DETECTION.

PAYMENT FOR ITEM 809 ADVANCE RADAR DETECTION, AS PER PLAN SHALL BE MADE AT THE CONTRACT UNIT PRICE FOR EACH UNIT, COMPLETE AND IN PLACE INCLUDING ALL REQUIRED CABINET HARDWARE, MOUNTING BRACKETS, CABLES, CONDUIT, CONNECTIONS TESTED AND ACCEPTED, AND ANY OTHER NECESSARY HARDWARE TO ESTABLISH A FULLY FUNCTIONAL DETECTION SYSTEM.

**ITEM 809 STOP-LINE RADAR DETECTION, AS PER PLAN**

THIS ITEM OF WORK SHALL CONSIST OF FURNISHING AND INSTALLING A WAVETRONIX SMARTSENSOR MATRIX DETECTION UNIT. THE DETECTION UNIT SHALL INCLUDE THE FOLLOWING:

1. POWER SHALL BE PROVIDED FROM THE TRAFFIC CABINET.
2. ALL REQUIRED INPUTS CARDS SHALL BE INCLUDED IN THE TRAFFIC CABINET AND SHALL BE COMPATIBLE WITH CALTRANS, NEMA TS1 AND NEMA TS2 DETECTOR RACKS. THE CARDS SHALL PROVIDE TRUE PRESENCE DETECTOR CALLS OR CONTACT CLOSURE TO THE TRAFFIC CONTROLLER.
3. THE UNIT SHALL BE MOUNTED DIRECTLY TO A POLE OR MAST ARM, AS RECOMMENDED BY THE MANUFACTURER. CABLE(S) SHALL BE PROVIDED AS REQUIRED AND RECOMMENDED BY THE MANUFACTURER.
4. SURGE PROTECTION DEVICES, AS RECOMMENDED BY THE MANUFACTURER SHALL BE INCLUDED BOTH AT THE POLE WHERE THE UNIT IS LOCATED TO PROTECT THE UNIT AND IN THE TRAFFIC CABINET TO PROTECT THE CABINET ELECTRONICS.
5. THE MANUFACTURER'S REPRESENTATIVE SHALL BE ON SITE DURING INSTALLATION AND TESTING AND SHALL PROVIDE ONSITE TRAINING ON THE SETUP, OPERATION AND MAINTENANCE OF THE UNIT.
6. A SERIAL TO ETHERNET COMMUNICATIONS MODULE AND ETHERNET CABLE (MINIMUM 7 FEET).
7. THE POWER SUPPLY AND COMMUNICATION MODULES SHALL BE SECURED TO A SINGLE PANEL THAT CAN BE MOUNTED INTERIOR TO THE TRAFFIC CABINET. THE PANEL SHALL INCLUDE MODULAR-PLUG STYLE CONNECTIONS FOR UP TO FOUR (4) SENSOR CABLES. ADDITIONAL SENSORS MAY BE HARD-WIRED TO

THE COMMUNICATION MODULES, AS NECESSARY.  
8. THE CONTRACTOR SHALL INSTALL THE RADAR DETECTION PRIOR TO MILLING/DISABLING EXISTING LOOPS.  
9. THE INSTALLATION SHALL INCLUDE ALL CONTROLLER PROGRAMMING FOR COMPLETE INSTALLATION, WHICH INCLUDES MODIFICATIONS FOR REMOVAL OF EXISTING DETECTION.

PAYMENT FOR ITEM 809 STOP-LINE RADAR DETECTION, AS PER PLAN SHALL BE MADE AT THE CONTRACT UNIT PRICE FOR EACH UNIT, COMPLETE AND IN PLACE INCLUDING ALL REQUIRED CABINET HARDWARE, MOUNTING BRACKETS, CABLES, CONDUIT AND CONNECTIONS TESTED AND ACCEPTED.

**GUARANTEE**

THE CONTRACTOR SHALL GUARANTEE THAT THE TRAFFIC CONTROL SYSTEM INSTALLED AS PART OF THIS CONTRACT SHALL OPERATE SATISFACTORILY FOR A PERIOD OF 120 DAYS FOLLOWING COMPLETION OF THE 10-DAY PERFORMANCE TEST. IN THE EVENT OF UNSATISFACTORY OPERATION THE CONTRACTOR SHALL CORRECT FAULTY INSTALLATIONS, MAKE REPAIRS AND REPLACE DEFECTIVE PARTS WITH NEW PARTS OF EQUAL OR BETTER QUALITY.

EQUIPMENT, MATERIAL, AND LABOR COSTS INCURRED IN CORRECTING AN UNSATISFACTORY OPERATION SHALL BE BORNE BY THE CONTRACTOR.

THE GUARANTEE SHALL COVER THE FOLLOWING ITEMS OF THE TRAFFIC CONTROL SYSTEM: CONTROLLER, CABINET, UNINTERRUPTIBLE POWER SUPPLY, VEHICLE DETECTION EQUIPMENT, LED LAMP UNITS, NETWORK AND COMMUNICATION/INTERCONNECT EQUIPMENT.

CUSTOMARY MANUFACTURER'S GUARANTEES FOR THE FOREGOING ITEMS SHALL BE TURNED OVER TO THE STATE OR THE MAINTAINING AGENCY FOLLOWING ACCEPTANCE OF THE EQUIPMENT.

THE COST OF GUARANTEEING THE TRAFFIC CONTROL SYSTEM WILL BE INCIDENTAL TO AND INCLUDED IN THE CONTRACT UNIT PRICE OF THE VARIOUS ITEMS MAKING UP THE SYSTEM.

**GROUNDING AND BONDING**

THE REQUIREMENTS OF THE CONSTRUCTION AND MATERIAL SPECIFICATIONS (GMS) AND THE TC SERIES OF STANDARD CONSTRUCTION DRAWINGS ARE MODIFIED AS FOLLOWS:

1. ALL METALLIC PARTS CONTAINING ELECTRICAL CONDUCTORS SHALL BE PERMANENTLY JOINED TO FORM AN EFFECTIVE GROUND FAULT CURRENT PATH BACK TO THE GROUNDED CONDUCTOR IN THE POWER SERVICE DISCONNECT SWITCH.  
A. PROVIDE AN EQUIPMENT GROUNDING CONDUCTOR IN METALLIC CONDUITS (725.04) IN ADDITION TO THE CONDUCTORS SPECIFIED AND BOND THE CONDUIT TO THIS GROUNDING CONDUCTOR.  
B. WHEN AN EQUIPMENT GROUNDING CONDUCTOR IS REQUIRED IN PLASTIC CONDUIT (725.05), THE INSTALLATION SHALL INCLUDE A SEPARATE EQUIPMENT GROUNDING CONDUCTOR IN ADDITION TO THE CONDUCTORS SPECIFIED.  
C. METALLIC CONDUIT CARRYING THE LOOP WIRES FROM IN THE PAVEMENT TO THE PULL BOX SPLICE LOCATION WILL ONLY BE BONDED AT THE PULL BOX END, AND WILL NOT CONTAIN AN EQUIPMENT GROUNDING CONDUCTOR.  
D. IF MULTIPLE CONDUIT RUNS BEGIN AND END AT THE SAME POINTS, ONLY ONE EQUIPMENT GROUNDING CONDUCTOR IS REQUIRED.  
E. IF AN EQUIPMENT GROUNDING CONDUCTOR IS NEEDED IN CONDUIT BETWEEN SIGNALIZED INTERSECTIONS FOR UNDERGROUND INTERCONNECT CABLE, THE GROUNDING SYSTEM FOR EACH SIGNALIZED INTERSECTION WILL BE SEPARATED ABOUT MIDWAY BETWEEN THE INTERSECTIONS.  
F. THE MESSENGER WIRE AT SIGNALIZED INTERSECTIONS WILL BE USED AS THE CONDUCTIVE PATH FROM CORNER TO CORNER IF CONDUIT IS NOT PROVIDED UNDER THE ROADWAY. WHEN CONDUIT CONNECTS THE CORNERS OF AN INTERSECTION, AN EQUIPMENT GROUNDING CONDUCTOR SHALL BE USED IN THE CONDUIT.
2. CONDUITS.  
A. THE 725.04 CONDUIT SHALL HAVE GROUNDING BUSHINGS INSTALLED AT ALL TERMINATION POINTS. THE BUSHING MATERIAL SHALL BE COMPATIBLE WITH GALVANIZED STEEL CONDUIT AND THE GROUNDING LUG MATERIAL SHALL BE COMPATIBLE FOR USE WITH COPPER WIRE. THREADED OR COMPRESSION TYPE BUSHINGS MAY BE USED.  
B. THE 725.05 CONDUIT SHALL HAVE THE INSIDE AND OUTSIDE DIAMETERS OF THE CONDUIT DEBURRED AT ALL TERMINATION POINTS.  
C. BOTH ENDS OF METALLIC CONDUIT SHALL BE BONDED

TO THE EQUIPMENT GROUNDING CONDUCTOR.  
D. METALLIC CONDUIT MAY BE BONDED TO METALLIC BOXES THROUGH THE USE OF CONDUIT FITTINGS UL APPROVED FOR THIS TYPE OF CONNECTION, WITH THE BOX BONDED TO THE EQUIPMENT GROUNDING CONDUCTOR.

3. WIRE FOR GROUNDING AND BONDING.  
A. USE INSULATED, COPPER WIRE FOR THE EQUIPMENT GROUNDING CONDUCTOR. BONDING JUMPERS IN BOXES AND ENCLOSURES MAY BE BARE OR INSULATED COPPER WIRE. WIRE SIZE SHALL BE AS FOLLOWS:  
I. USE 4 AWG BETWEEN THE POWER SERVICE AND SUPPORTS, POLES, PEDESTALS, CONTROLLER OR FLASHER CABINETS.  
II. USE A MINIMUM 8 AWG BETWEEN LOOP DETECTOR PULL BOXES AND THE FIRST CONDUIT THAT REQUIRES A LARGER SIZE AS SPECIFIED IN 3.A.I ABOVE.  
III. USE A MINIMUM 8 AWG BETWEEN THE "PREPARE TO STOP WHEN FLASHING" INSTALLATION (INCLUDING SUPPORT) AND THE FIRST CONDUIT THAT REQUIRES A LARGER SIZE AS SPECIFIED IN 3.A.I ABOVE.  
IV. THE INSULATION SHALL BE GREEN OR GREEN WITH YELLOW STRIPE(S). FOR 4 AWG OR LARGER, INSULATION MAY ALSO BE BLACK WITH GREEN TAPE/LABELS INSTALLED AT ALL ACCESS POINTS.  
B. IN A HIGHWAY LIGHTING SYSTEM, THE EQUIPMENT GROUNDING CONDUCTOR SHALL BE THE SAME WIRE SIZE AS THE DUCT CABLE OR DISTRIBUTION CABLE CIRCUIT CONDUCTORS, WITH THE MINIMUM CONDUCTOR SIZE OF 4 AWG. BONDING JUMPERS WILL BE MINIMUM SIZE 4 AWG.

4. GROUND ROD.  
A. A 3/4 INCH SCHEDULE 40 PVC CONDUIT WILL BE USED IN FOUNDATIONS AND CONCRETE WALLS FOR THE GROUNDING CONDUCTOR (GROUND WIRE) RACEWAY TO THE GROUND ROD. SHOULD METALLIC CONDUIT BE USED, BOTH ENDS OF THE CONDUIT SHALL BE BONDED TO THE GROUNDING CONDUCTOR.

- B. THE TYPICAL GROUNDING CONDUCTOR (GROUND WIRE) SHALL BE 4 AWG INSULATED, COPPER.

5. THE GREEN CONDUCTOR IN SIGNAL CABLES (CONDUCTOR #4) SHALL NOT BE USED TO SUPPLY POWER TO A SIGNAL INDICATION. IT WILL BE CONNECTED TO THE SIGNAL BODY AS AN EQUIPMENT GROUND IN ALUMINUM HEADS AND IT WILL BE UNUSED IN PLASTIC HEADS. UNUSED CONDUCTORS SHALL BE GROUNDED IN THE CABINET. TYPICAL USE OF CONDUCTORS IS AS FOLLOWS:

COND. NO./COLOR/VEHICLE SIGNAL/PEDESTRIAN SIGNAL  
1/BLACK/GREEN BALL/#1 WALK  
2/WHITE/AC NEUTRAL/AC NEUTRAL  
3/RED/RED BALL/#1 DW/FDW  
4/GREEN/EQUIPMENT GROUND/EQUIPMENT GROUND  
5/ORANGE/YELLOW BALL/#2 DW FDW  
6/BLUE/GREEN ARROW/#2 WALK  
7/WHITE WITH BLACK STRIPE/YELLOW ARROW/NOT USED

6. POWER SERVICE AND DISCONNECT SWITCH.  
A. AT THE POWER SERVICE LOCATION, THE GROUNDING CONDUCTOR (GROUND WIRE) FROM THE DISCONNECT SWITCH NEUTRAL (AC-) BAR TO THE GROUND ROD SHALL BE A CONTINUOUS, UNSPLICED CONDUCTOR. IF SPLICED, IT SHALL BE AN EXOTHERMIC WELD BUTT SPLICE.  
B. THE SERVICE NEUTRAL (AC-) SHALL ONLY BE CONNECTED TO GROUND AT THE PRIMARY POWER SERVICE DISCONNECT SWITCH. I. NEMA CONTROLLER CABINETS: IF A POWER SERVICE DISCONNECT SWITCH IS LOCATED BEFORE THE CONTROLLER CABINET, THE NEUTRAL (AC-) AND THE GROUNDING BARS IN THE CONTROLLER CABINET SHALL NOT BE CONNECTED TOGETHER AS SHOWN IN NEMA TS-2, FIGURE 5-4.  
II. IF SECONDARY DISCONNECT SWITCHES ARE CONNECTED AFTER THE PRIMARY DISCONNECT SWITCH, THE NEUTRAL (AC-) SHALL ONLY BE GROUNDED AT THE PRIMARY SWITCH. EQUIPMENT GROUNDING CONDUCTORS SHALL BE BROUGHT TO THE PRIMARY SWITCH, BUT SHALL BE GROUNDED AT BOTH SECONDARY AND PRIMARY SWITCHES.

7. PAYMENT - ALL MATERIALS AND WORK REQUIRED TO COMPLETE THE EFFECTIVE GROUND FAULT CURRENT PATH SYSTEM ARE INCIDENTAL TO THE CONDUCTORS INSTALLED BY CONTRACT.

CALCULATED  
CWG  
CHECKED  
SAK

GENERAL NOTES

GEA -87 - 2.73

5  
20

L:\ODOT\19068303-00\_VAR-D12-D03-SftyDsgn\02\_GEA-87\110882\_Roadway\Sheets\110882\_CG001.dgn 9/15/2020 2:52:41 PM ghansel

SHEET NUM.										PART.		ITEM	ITEM EXT	GRAND TOTAL	UNIT	DESCRIPTION	SEE SHEET NO.	CALCULATED	CWG	CHECKED	SAK
2	3	7	13							01/SAF/OT	4BG7										
										<b>ROADWAY</b>											
LS										LS		201	11000	LS		CLEARING AND GRUBBING					
										<b>TRAFFIC CONTROL</b>											
		14								14		630	03100	14	FT	GROUND MOUNTED SUPPORT, NO. 3 POST					
			5							5		630	79101	5	EACH	SIGN HANGER ASSEMBLY, MAST ARM, AS PER PLAN	3				
			4							4		630	79500	4	EACH	SIGN SUPPORT ASSEMBLY, POLE MOUNTED					
			2							2		630	79501	2	EACH	SIGN SUPPORT ASSEMBLY, POLE MOUNTED, AS PER PLAN	3				
		6	61							67		630	80100	67	SF	SIGN, FLAT SHEET					
			2							2		630	80500	2	EACH	SIGN, DOUBLE FACED, STREET NAME					
		12								12		630	84900	12	EACH	REMOVAL OF GROUND MOUNTED SIGN AND DISPOSAL					
		10								10		630	86002	10	EACH	REMOVAL OF GROUND MOUNTED POST SUPPORT AND DISPOSAL					
		8								8		630	87500	8	EACH	REMOVAL OF POLE MOUNTED SIGN AND DISPOSAL					
		62								62		644	00500	62	FT	STOP LINE, 24"					
		138								138		644	30000	138	FT	REMOVAL OF PAVEMENT MARKING					
		2								2		644	30020	2	EACH	REMOVAL OF PAVEMENT MARKING					
										<b>TRAFFIC SIGNALS</b>											
			122							122		625	25500	122	FT	CONDUIT, 3", 725.04					
			281							281		625	25906	281	FT	CONDUIT, JACKED OR DRILLED, 725.051, 4"					
			61							61		625	29000	61	FT	TRENCH					
			3							3		625	30700	3	EACH	PULL BOX, 725.08, 18"					
			10							10		625	31510	10	EACH	PULL BOX REMOVED					
			5							5		625	32000	5	EACH	GROUND ROD					
			61							61		625	36000	61	FT	PLASTIC CAUTION TAPE					
			4							4		632	05006	4	EACH	VEHICULAR SIGNAL HEAD, (LED), 3-SECTION, 12" LENS, 1-WAY, POLYCARBONATE, BLACK, WITH BACKPLATE					
			4							4		632	05086	4	EACH	VEHICULAR SIGNAL HEAD, (LED), 5-SECTION, 12" LENS, 1-WAY, POLYCARBONATE, BLACK, WITH BACKPLATE					
			8							8		632	20731	8	EACH	PEDESTRIAN SIGNAL HEAD (LED), TYPE D2, COUNTDOWN, AS PER PLAN	4				
			8							8		632	25000	8	EACH	COVERING OF VEHICULAR SIGNAL HEAD					
			8							8		632	25010	8	EACH	COVERING OF PEDESTRIAN SIGNAL HEAD					
			610							610		632	40700	610	FT	SIGNAL CABLE, 7 CONDUCTOR, NO. 14 AWG					
			650							650		632	40900	650	FT	SIGNAL CABLE, 9 CONDUCTOR, NO. 14 AWG					
			4							4		632	64010	4	EACH	SIGNAL SUPPORT FOUNDATION					
			240							240		632	68200	240	FT	POWER CABLE, 2 CONDUCTOR, NO. 6 AWG					
			300							300		632	69800	300	FT	SERVICE CABLE, 3 CONDUCTOR, NO. 6 AWG					
			1							1		632	70000	1	EACH	POWER SERVICE					
			3							3		632	72131	3	EACH	SIGNAL SUPPORT, TYPE TC-81.22, DESIGN 12, AS PER PLAN	4				
			1							1		632	72141	1	EACH	SIGNAL SUPPORT, TYPE TC-81.22, DESIGN 13, AS PER PLAN	4				
			1							1		632	90100	1	EACH	REMOVAL OF TRAFFIC SIGNAL INSTALLATION					
			1							1		633	65523	1	EACH	CABINET, TYPE 332L, AS PER PLAN	4				
			1							1		633	67100	1	EACH	CABINET FOUNDATION					
			1							1		633	67201	1	EACH	CONTROLLER WORK PAD, AS PER PLAN	4				
			1							1		633	68511	1	EACH	COMMUNICATIONS, AS PER PLAN	4				
			1							1		633	75001	1	EACH	UNINTERRUPTIBLE POWER SUPPLY (UPS), 1000 WATT, AS PER PLAN	4				
			4							4		809	69001	4	EACH	ADVANCE RADAR DETECTION, AS PER PLAN	5				
			4							4		809	69101	4	EACH	STOP LINE RADAR DETECTION, AS PER PLAN	5				
			1							1		809	69123	1	EACH	ATC V6.24 CONTROLLER, AS PER PLAN	5				
			4							4		809	69200	4	EACH	EMERGENCY VEHICLE PREEMPTION					
			4							4		809	69210	4	EACH	PREEMPT RECEIVING UNIT					
			730							730		809	69220	730	FT	PREEMPT DETECTOR CABLE					
			1							1		809	69230	1	EACH	PREEMPT PHASE SELECTOR					
			4							4		809	69240	4	EACH	PREEMPT CONFIRMATION LIGHT					
										<b>INCIDENTALS</b>											
	LS									LS		614	11000	LS		MAINTAINING TRAFFIC					
	50									50		614	11110	50	HOUR	LAW ENFORCEMENT OFFICER WITH PATROL CAR FOR ASSISTANCE					
8										8		619	16011	8	MNTH	FIELD OFFICE, TYPE B, AS PER PLAN	2				
										LS		623	10000	LS		CONSTRUCTION LAYOUT STAKES AND SURVEYING					
										LS		624	10000	LS		MOBILIZATION					

GENERAL SUMMARY

GEA - 87 - 2.73

**SIGN SUBSUMMARY**

SHEET NO.	REFERENCE NO.	LOCATION	STATION	SIDE	CODE	SIZE (INCHES)	630	630	630	630	630										
							GROUND MOUNTED SUPPORT, NO. 3 POST FT	SIGN, FLAT SHEET SF	REMOVAL OF GROUND MOUNTED SIGN AND DISPOSAL EACH	REMOVAL OF GROUND MOUNTED POST SUPPORT AND DISPOSAL EACH	REMOVAL OF POLE MOUNTED SIGN AND DISPOSAL EACH										
8	S-1	SR-87	143+13	LT	M3-4-24 M1-5-24-2	24x12 24x24	14	2 4													
8	R-1	SR-87	143+59	LT	M1-5-30-3, M6-4-21	-					2										
8	R-2	SR-87	143+65	LT	R9-3-18, R9-3BP-18	-															
8	R-3	SR-87	143+64	RT	R3-H8BH-36	-					1	2									
8	R-4	SR-87	143+68	RT	R9-3-18, R9-3BP-18	-					2	1									
8	R-5	SR-87	144+53	LT	M1-5-30-2, M6-4-21	-					2	1									
8	R-6	SR-87	144+65	RT	M1-5-30-3, M6-4-21	-							2								
8	R-7	SR-87	144+66	LT	R3-H8BH-36	-					1	2									
8	R-8	SR-306	419+67	RT	R3-H8BH-36, R10-H6BL-36	-					2	2									
8	R-9	SR-306	420+69	RT	D3-1, D3-1	-					2	1									
8	R-10	SR-306	429+84	LT	M1-5-30-3, M6-4-21, R3-H8BH-36, R10-H6BL-36	-								4							
<b>TOTALS CARRIED TO GENERAL SUMMARY</b>							14	6	12	10	8										

**PAVEMENT MARKING SUBSUMMARY**

SHEET NO.	REFERENCE NO.	LOCATION	STATION		SIDE	644	644	644														
			FROM	TO		STOP LINE, 24"	REMOVAL OF PAVEMENT MARKING	REMOVAL OF PAVEMENT MARKING														
						FT	FT	EACH														
8	ST-1	SR-87	143+61		RT	12																
8	ST-2	SR-306	419+50		MID	12																
8	ST-3	SR-306	419+74		RT	12																
8	ST-4	SR-306	421+06		MID	12																
8	ST-5	SR-87	144+69		LT	14																
8	RM-1	SR-87	143+61	143+65	RT		16															
8	RM-2	SR-306	419+50	419+81	BOTH		70	1														
8	RM-3	SR-306	420+87	421+06	BOTH		32	1														
8	RM-4	SR-87	144+65	144+69	LT		20															
<b>TOTALS CARRIED TO GENERAL SUMMARY</b>						62	138	2														

CALCULATED  
CWG  
CHECKED  
SAK

**SIGN AND PAVEMENT MARKING SUBSUMMARY**

**GEA -87 -2.73**

L:\ODOT\19068303-00\_VAR-D12-D03-SfyDsgn\02\_GEA-87\110882\_Roadway\Sheets\110882\_TS001.dgn 9/15/2020 2:52:42 PM ghonsel

L:\ODOT\19068303-00\_VAR-D12-D03-SftyDsgn\02\_GEA-87\110882\_Roadway\Sheets\110882\_TP001.dgn 9/15/2020 2:52:43 PM ghansel

MARKING LEGEND

(ST) ITEM 644, 24" STOP LINE

SIGNING LEGEND

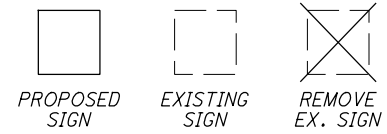

(S)

(R)



PROPOSED M3-4-24 MI-5-24-2 STA. 143+13



REMOVE Existing MI-5-30-3 M6-4-21

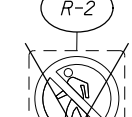

REMOVE Existing R9-3-18 R9-3bP-18

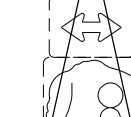

REMOVE Existing R3-H8bh-36 R10-H6bL-36



PROPOSED M3-4-24 MI-5-24-2 STA. 143+13

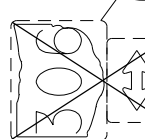

REMOVE Existing MI-5-30-3 M6-4-21



REMOVE Existing R9-3-18 R9-3bP-18

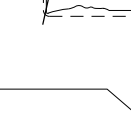

REMOVE Existing R3-H8bh-36 R10-H6bL-36

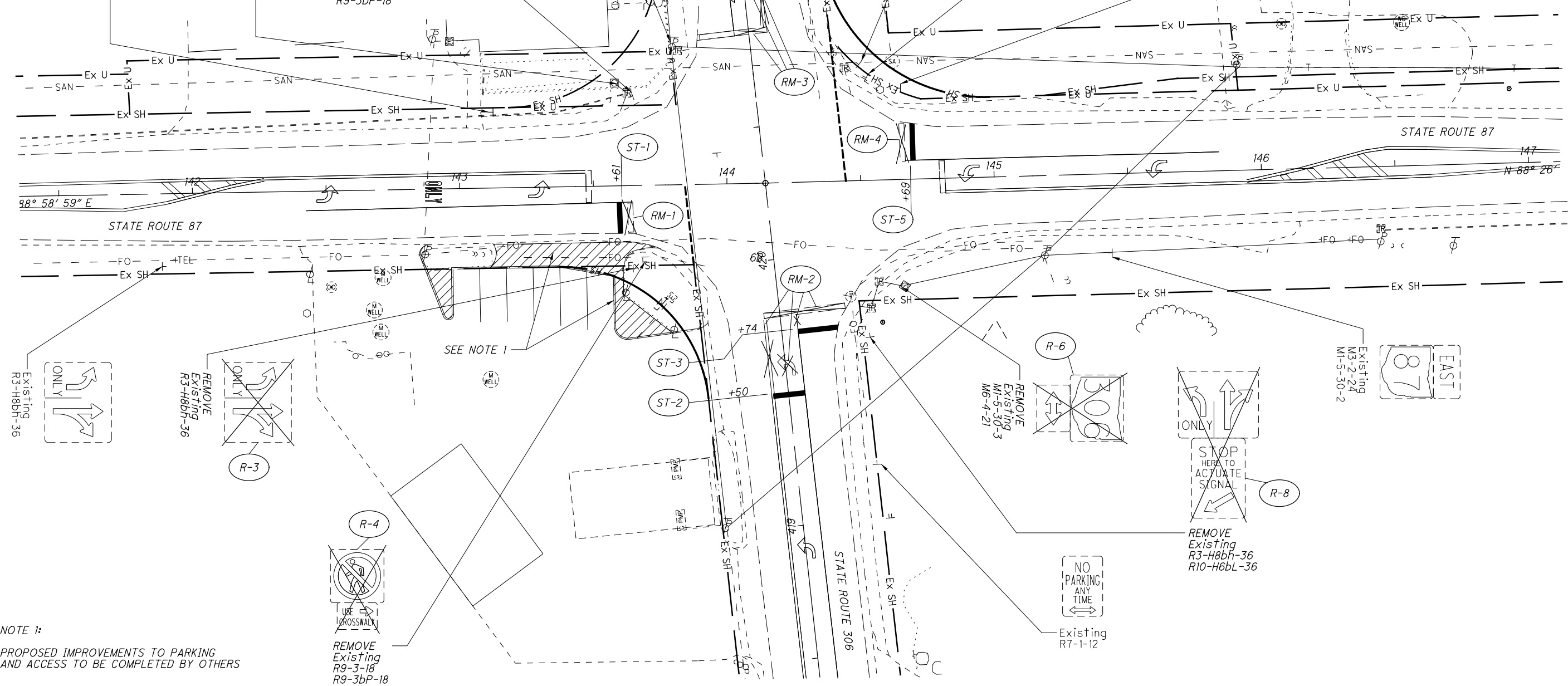

NOTE 1:  
PROPOSED IMPROVEMENTS TO PARKING AND ACCESS TO BE COMPLETED BY OTHERS

REMOVE Existing R9-3-18 R9-3bP-18

NO PARKING ANY TIME

REMOVE Existing R3-H8bh-36 R10-H6bL-36



TRAFFIC CONTROL PLAN  
STATE ROUTE 87 & STATE ROUTE 306

GEA-87-2.7.3

L:\ODOT\19068303-00\_VAR-D12-D03-SftyDsgn\02\_GEA-87\110882-Roadway\Sheets\110882\_XX001.dgn 9/15/2020 2:52:44 PM ghansel

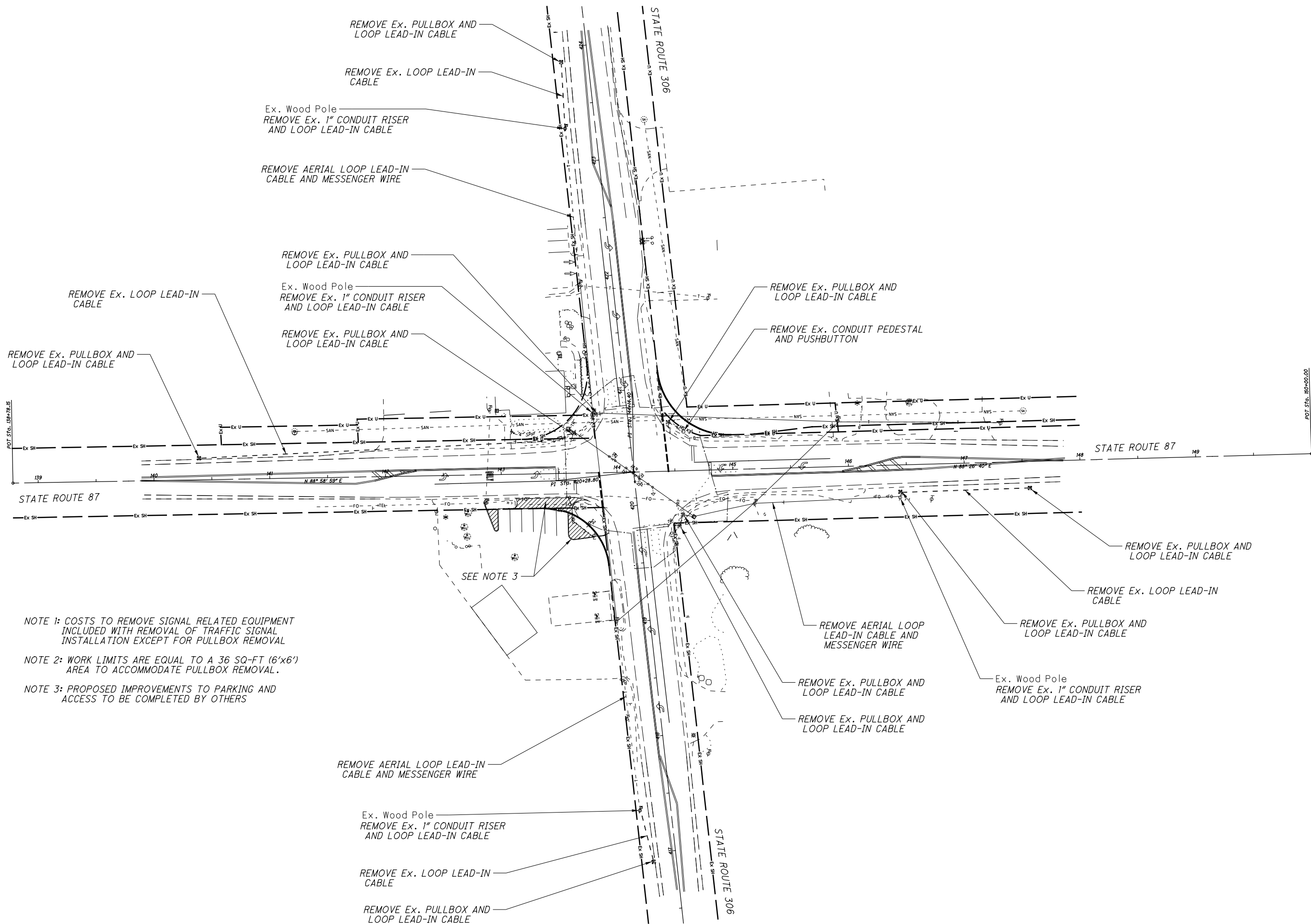

REMOVE Ex. PULLBOX AND LOOP LEAD-IN CABLE

REMOVE Ex. LOOP LEAD-IN CABLE

REMOVE Ex. PULLBOX AND LOOP LEAD-IN CABLE

REMOVE Ex. LOOP LEAD-IN CABLE

Ex. Wood Pole  
REMOVE Ex. 1" CONDUIT RISER AND LOOP LEAD-IN CABLE

REMOVE AERIAL LOOP LEAD-IN CABLE AND MESSENGER WIRE

REMOVE Ex. PULLBOX AND LOOP LEAD-IN CABLE

Ex. Wood Pole  
REMOVE Ex. 1" CONDUIT RISER AND LOOP LEAD-IN CABLE

REMOVE Ex. PULLBOX AND LOOP LEAD-IN CABLE

REMOVE Ex. PULLBOX AND LOOP LEAD-IN CABLE

REMOVE Ex. CONDUIT PEDESTAL AND PUSHBUTTON

NOTE 1: COSTS TO REMOVE SIGNAL RELATED EQUIPMENT INCLUDED WITH REMOVAL OF TRAFFIC SIGNAL INSTALLATION EXCEPT FOR PULLBOX REMOVAL

NOTE 2: WORK LIMITS ARE EQUAL TO A 36 SQ-FT (6'x6') AREA TO ACCOMMODATE PULLBOX REMOVAL.

NOTE 3: PROPOSED IMPROVEMENTS TO PARKING AND ACCESS TO BE COMPLETED BY OTHERS

REMOVE AERIAL LOOP LEAD-IN CABLE AND MESSENGER WIRE

Ex. Wood Pole  
REMOVE Ex. 1" CONDUIT RISER AND LOOP LEAD-IN CABLE

REMOVE Ex. LOOP LEAD-IN CABLE

REMOVE Ex. PULLBOX AND LOOP LEAD-IN CABLE

REMOVE Ex. PULLBOX AND LOOP LEAD-IN CABLE

REMOVE Ex. LOOP LEAD-IN CABLE

REMOVE Ex. PULLBOX AND LOOP LEAD-IN CABLE

Ex. Wood Pole  
REMOVE Ex. 1" CONDUIT RISER AND LOOP LEAD-IN CABLE

REMOVE AERIAL LOOP LEAD-IN CABLE AND MESSENGER WIRE

REMOVE Ex. PULLBOX AND LOOP LEAD-IN CABLE

REMOVE Ex. PULLBOX AND LOOP LEAD-IN CABLE



CALCULATED  
CWG  
CHECKED  
SAK

**TRAFFIC SIGNAL  
DETECTION DEMOLITION PLAN**

**GEA-87-2.73**

**SIGNS**

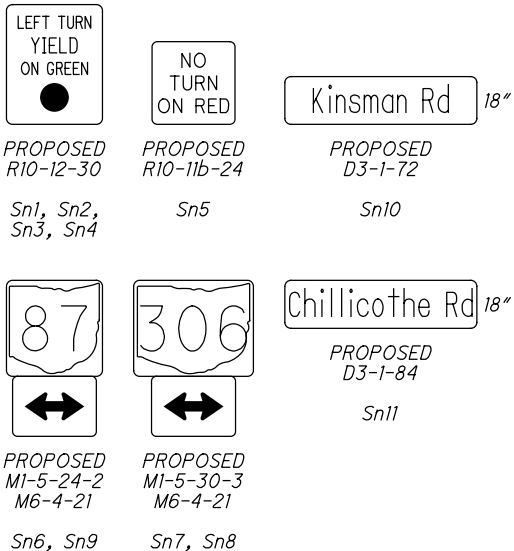

**SIGNAL HEADS**

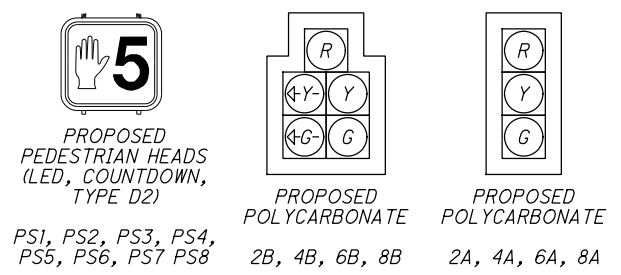

NOTE 1: POWER SHALL BE OBTAINED FROM THE EXISTING EXISTING TRANSFORMER AT APPROXIMATELY STA. 141+08 30' RT

NOTE 2: PROPOSED IMPROVEMENTS TO PARKING AND ACCESS TO BE COMPLETED BY OTHERS.

PROP. SIGNAL SUPPORT, SP1, AS PER PLAN  
PROP. POLE MOUNTED SIGN, Sn7  
PROP. PEDESTRIAN SIGNAL HEADS, PS1 AND PS2, AS PER PLAN  
PROP. POWER SERVICE, AS PER PLAN, NOTE 1  
PROP. ADVANCED RADAR DETECTION, R1, AS PER PLAN  
PROP. STOP LINE RADAR DETECTION, R2, AS PER PLAN

PROP. SIGNAL SUPPORT, SP2, AS PER PLAN  
PROP. POLE MOUNTED SIGN, Sn6  
PROP. POLE MOUNTED STREET NAME SIGNS, Sn10 AND Sn11, AS PER PLAN  
PROP. PEDESTRIAN SIGNAL HEADS, PS3 AND PS4, AS PER PLAN  
PROP. ADVANCED RADAR DETECTION, R3, AS PER PLAN  
PROP. STOP LINE RADAR DETECTION, R4, AS PER PLAN

PROP. 2-3" GALV. CONDUIT (10 FT)

PROP. CONC. PULLBOX, 18", PB1

PROP. 4" CONDUIT, JACKED OR DRILLED (83 FT)

PROP. 2-3" GALV. CONDUIT (28 FT)

PROP. CONC. PULLBOX, 18", PB2

PROP. 4" CONDUIT, JACKED OR DRILLED (78 FT)

PROP. GROUND-MOUNTED CONTROLLER AND CABINET, AS PER PLAN  
PROP. 24" PULLBOX  
PROP. WORK PAD, AS PER PLAN  
PROP. UPS, AS PER PLAN  
PROP. COMMUNICATIONS, AS PER PLAN

PROP. 2-3" GALV. CONDUIT (13 FT)

PROP. SIGNAL SUPPORT, SP3, AS PER PLAN  
PROP. POLE MOUNTED SIGN, Sn8  
PROP. PEDESTRIAN SIGNAL HEADS, PS5 AND PS6, AS PER PLAN  
PROP. ADVANCED RADAR DETECTION, R5, AS PER PLAN  
PROP. STOP LINE RADAR DETECTION, R6, AS PER PLAN

PROP. 4" CONDUIT, JACKED OR DRILLED (120 FT)

PROP. SIGNAL SUPPORT, SP4, AS PER PLAN  
PROP. POLE MOUNTED SIGN, Sn9  
PROP. PEDESTRIAN SIGNAL HEADS, PS7 AND PS8, AS PER PLAN  
PROP. ADVANCED RADAR DETECTION, R7, AS PER PLAN  
PROP. STOP LINE RADAR DETECTION, R8, AS PER PLAN

**PULLBOX TABLE**

PULL BOX #	STATION	SIDE	OFFSET	SIZE (IN.)
PB1	143+64	LT	45	18
PB2	144+18	LT	35	18
PB3	143+68	RT	35	18

**LEGEND**

	PROP	EXIST
TRAFFIC SIGNAL, 2 UNIT, 3 UNIT, OR PHB HEAD, 12"		
TRAFFIC SIGNAL, 4 OR 5 UNIT HEAD, 12"		
SIGNAL SUPPORT POLE		
PEDESTRIAN HEAD		
PREEMPTION DETECTOR		
CONTROLLER CABINET AND WORK PAD (332L)		
TRAFFIC PULL BOX		
DILEMMA ZONE RADAR DETECTION UNIT		
STOP-LINE RADAR DETECTION UNIT		
DETECTION ZONE		

SIGNAL TIMING CHART (TEM FORM 496-3)

INTERSECTION: SR-87 & SR-306		OHIO DEPARTMENT OF TRANSPORTATION							
MAINTAINING AGENCY:		DUAL ENTRY: YES		PHASES: 2&6, 4&8					
START UP		REST IN RED:		RING 1		RING 2			
START IN: ALL-RED FLASH		OVERLAP:		A		B		C D	
TIME FOR: FLASH, ALL RED (SEC.): 9, 6		PHASES:		-		-		-	
FIRST PHASE(S): 2, 6		PHASES:		-		-		-	
COLOR DISPLAYED: GREEN		PHASES:		-		-		-	
INTERVAL OR FEATURE		CONTROLLER MOVEMENT NO.							
INTERSECTION MOVEMENT (PHASE)		1	2	3	4	5	6	7	8
DIRECTION		SB LT	NB	WB LT	EB	NB LT	SB	EB LT	WB
MINIMUM GREEN (INITIAL) (SEC.)		7	26	7	23	7	26	7	23
ADDED INITIAL *(SEC./ACTUATION)		-	-	-	-	-	-	-	-
MAXIMUM INITIAL (SEC.)		-	-	-	-	-	-	-	-
PASSAGE TIME (PRESET GAP) (SEC.)		0.1	3	0.1	3	0.1	3	0.1	3
TIME BEFORE REDUCTION *(SEC.)		-	-	-	-	-	-	-	-
MINIMUM GAP *(SEC.)		-	-	-	-	-	-	-	-
TIME TO REDUCE *(SEC.)		-	-	-	-	-	-	-	-
MAXIMUM GREEN I (SEC.)		10	45	10	40	10	45	10	40
MAXIMUM GREEN II (SEC.)		10	45	10	40	10	45	10	40
YELLOW CHANGE (SEC.)		3.0	5.0	3.0	5.0	3.0	5.0	3.0	5.0
ALL RED CLEARANCE (SEC.)		2.0	1.0	2.0	1.0	2.0	1.0	2.0	1.0
DELAYED GREEN (LPD) ** (SEC.)		-	-	-	-	-	-	-	-
FLASHING YELLOW ARROW DELAY *** (SEC.)		-	-	-	-	-	-	-	-
WALK (SEC.)		-	9	-	8	-	9	-	8
PEDESTRIAN CLEARANCE (SEC.)		-	17	-	15	-	17	-	15
RECALL	MAXIMUM (ON/OFF)	OFF	OFF	OFF	OFF	OFF	OFF	OFF	OFF
	MINIMUM (ON/OFF)	OFF	ON	OFF	ON	OFF	ON	OFF	ON
	PEDESTRIAN (ON/OFF)	OFF	ON	OFF	ON	OFF	ON	OFF	ON
MEMORY (ON/OFF)		-	-	-	-	-	-	-	-

PHASING DIAGRAM (TYPICAL)

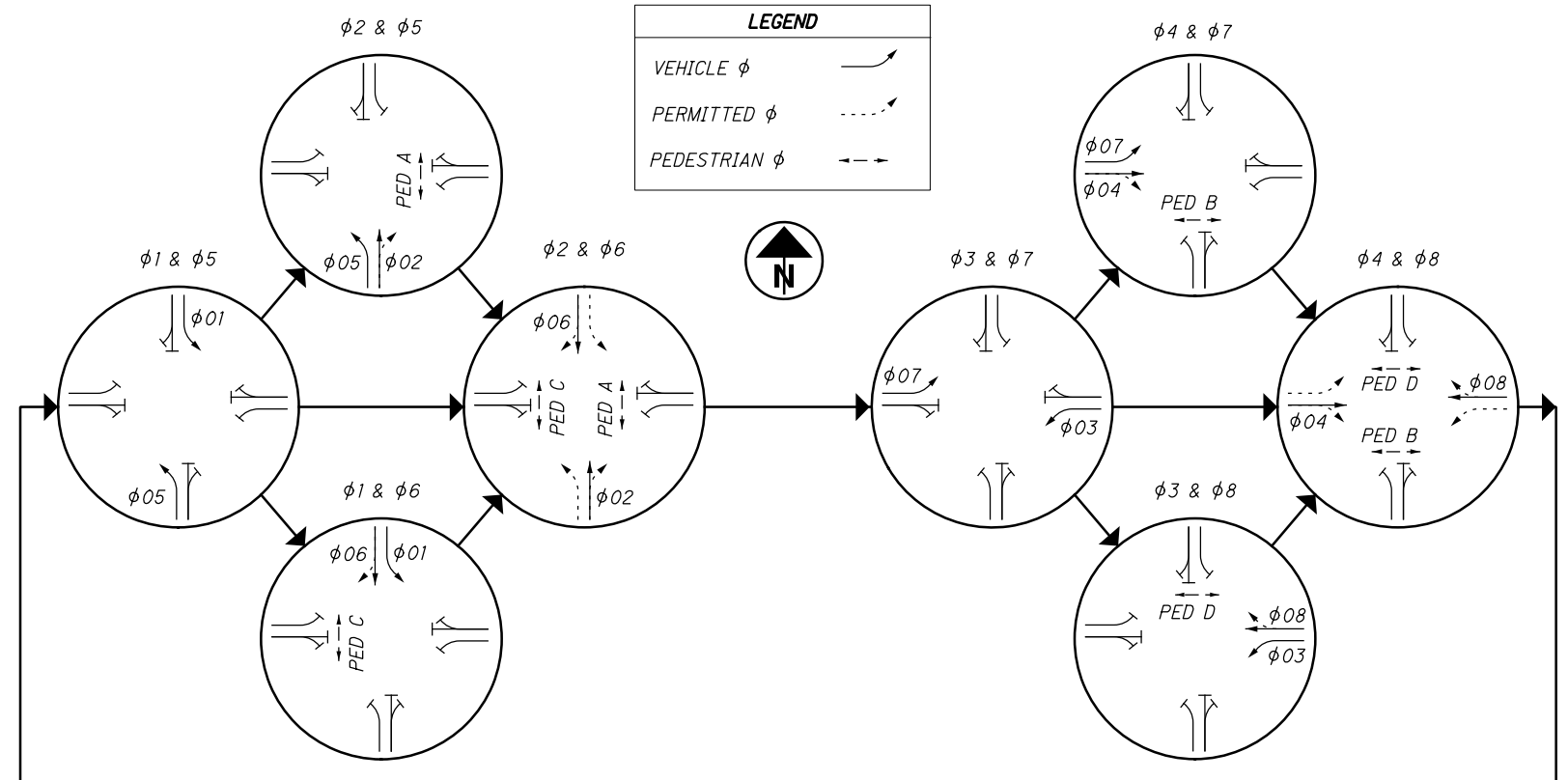

RADAR DETECTION CHART (TEM FORM 496-4)

DETECTION ZONE	MOVEMENT	PULSE OR PRESENCE	ASSOCIATED PHASE	DELAY PROGRAMMED IN CONTROLLER (SEC.)	EXTENSION PROGRAMMED IN CONTROLLER (SEC.)	DELAY INHIBITED PHASE	PURPOSE	DETECTION ZONE LENGTH (FT)
RDZ1A	SB LT	PRESENCE	1	-	0.1	1	SL	70
RDZ2A	NB	PRESENCE	2	-	3	-	ADV	150
RDZ3A	WB LT	PRESENCE	3	-	0.1	3	SL	70
RDZ4A	EB	PRESENCE	4	-	3	-	ADV	150
RDZ5A	NB LT	PRESENCE	5	-	0.1	5	SL	70
RDZ6A	SB	PRESENCE	6	-	3	-	ADV	150
RDZ7A	EB LT	PRESENCE	7	-	0.1	7	SL	70
RDZ8A	WB	PRESENCE	8	-	3	-	ADV	150

NOTE: ADVANCED DILEMMA ZONE SPEED THRESHOLD >35 MPH  
PURPOSE: STOP-LINE OR ADVANCED DETECTION

NOTES:

- ALL LEFT-TURN MOVEMENTS SHALL BE ACTUATED. THE THROUGH MOVEMENTS SHOULD HAVE MIN RECALL ACTIVE TO REST IN GREEN.
- FOR PROTECTED/PERMISSIVE PHASES, IMPLEMENT CALL OMTS TO AVOID YELLOW BALL TRAP.
- ENABLE phi 1, phi 3 & phi 5, phi 7 DETECTOR SWITCHING TO ALLOW phi 1 & phi 5 TO EXTEND phi 2 & phi 6 OR phi 3 & phi 7 TO EXTEND phi 4 & phi 8, RESPECTIVELY, WHEN ALLOCATED GREEN TIME FOR LEFT TURN PHASES ARE EXHAUSTED.
- RADAR DETECTION UNITS FOR DILEMMA ZONE DETECTION SHALL PLACE A CONSTANT CALL TO THE CONTROLLER WHEN VEHICLES TRAVEL TIMES TO THE STOP BAR ARE BETWEEN 2.5 AND 6 SECONDS. SPEED TRIGGER SHALL BE SET FOR VEHICLES TRAVELING 35 MPH AND GREATER.
- RADAR SHALL HAVE QUEUE DETECTION CONFIGURED AND A ZONE PLACED AT 100-200 FEET FROM STOP BAR FOR SLOW MOVING VEHICLE EXTENSIONS. SPEED TRIGGER SHALL BE SET AT 1-35 MPH.
- ALL DETECTOR DELAYS SHALL BE PLACED IN THE CONTROLLER.
- FOR ANY ENTRY TO FLASHING OPERATION, PROGRAMMING SHALL RUN MINOR STREET GREEN (phi 4 & phi 8), ALL-RED CLEARANCE, AND THEN FLASHING OPERATION.

CALCULATED  
CWG  
CHECKED  
SAK

TRAFFIC SIGNAL PLAN DETAILS  
STATE ROUTE 87 & STATE ROUTE 306

GEA-87-2.7.3

L:\ODOT\19068303-00\_VAR-D12-D03-SftyDsgn\02\_GEA-87\110882\_Roadway\Sheets\110882\_CP002.dgn 9/21/2020 11:04:48 AM ghansel

L:\ODOT\19068303-00\_VAR-D12-D03-SftyDsgn\02\_GEA-87\110882\_Roadway\Sheets\110882\_CP003.dgn 9/21/2020 11:04:49 AM ghnasel

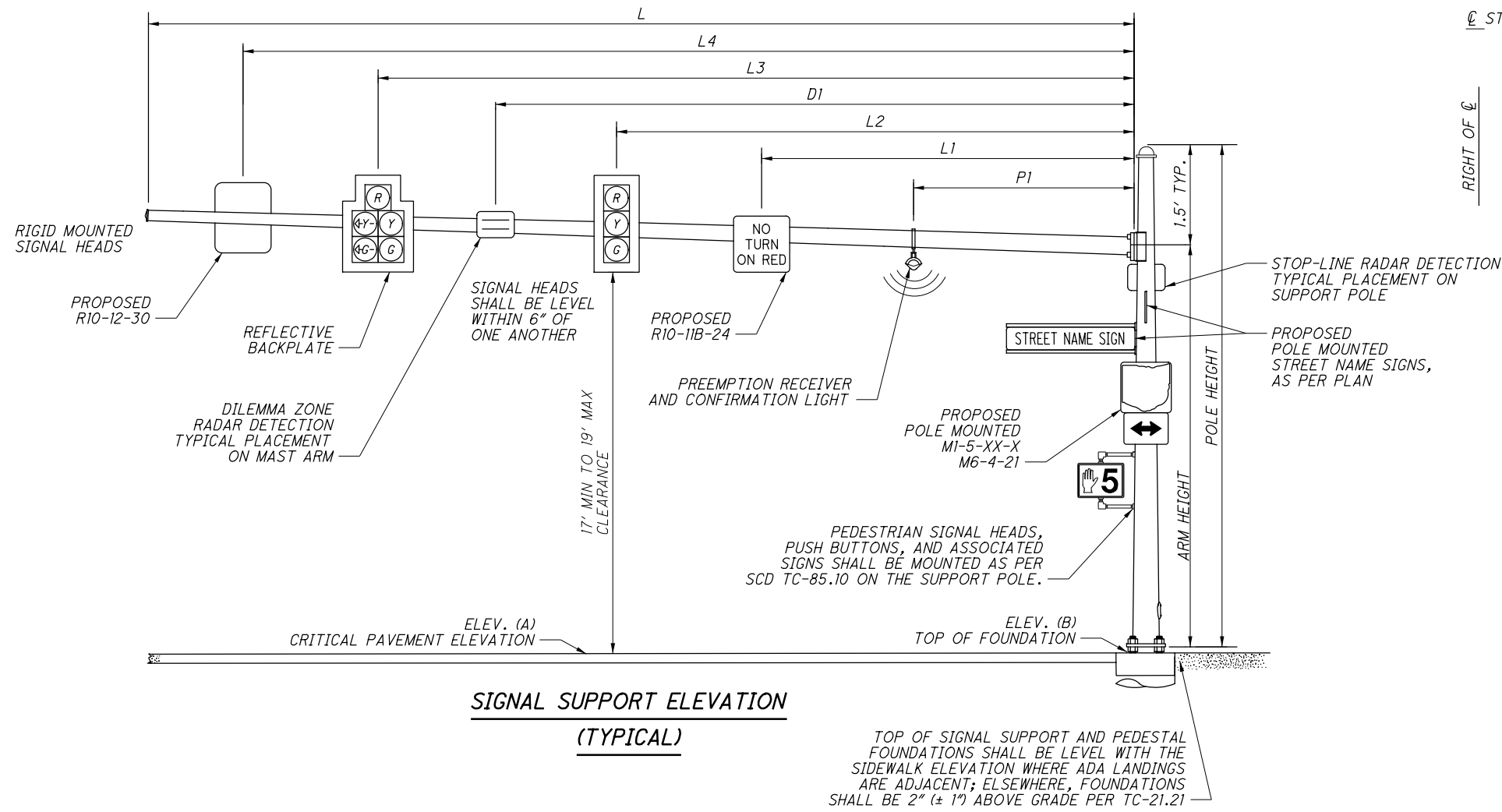

**SIGNAL SUPPORT ELEVATION (TYPICAL)**

TOP OF SIGNAL SUPPORT AND PEDESTAL FOUNDATIONS SHALL BE LEVEL WITH THE SIDEWALK ELEVATION WHERE ADA LANDINGS ARE ADJACENT; ELSEWHERE, FOUNDATIONS SHALL BE 2" (± 1") ABOVE GRADE PER TC-21.21

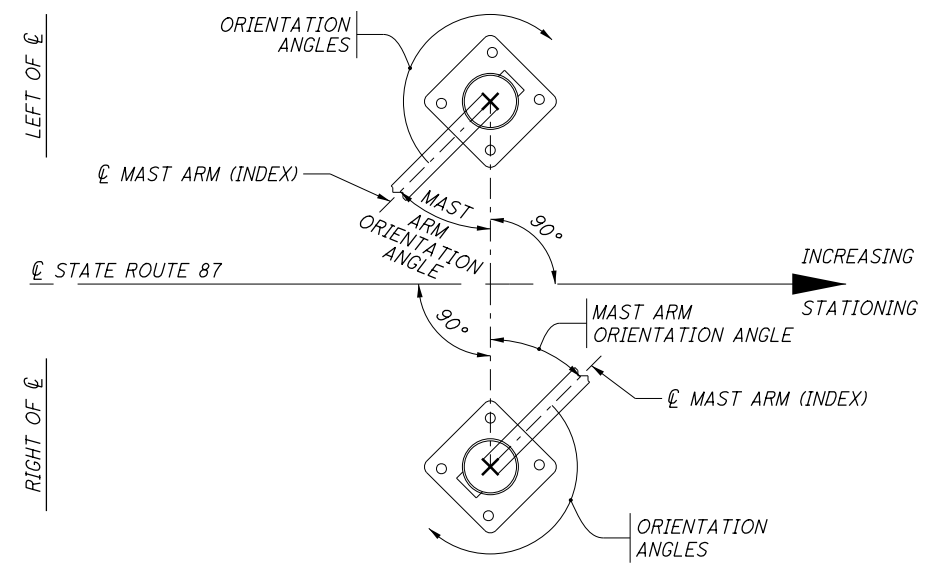

**POLE ORIENTATION**

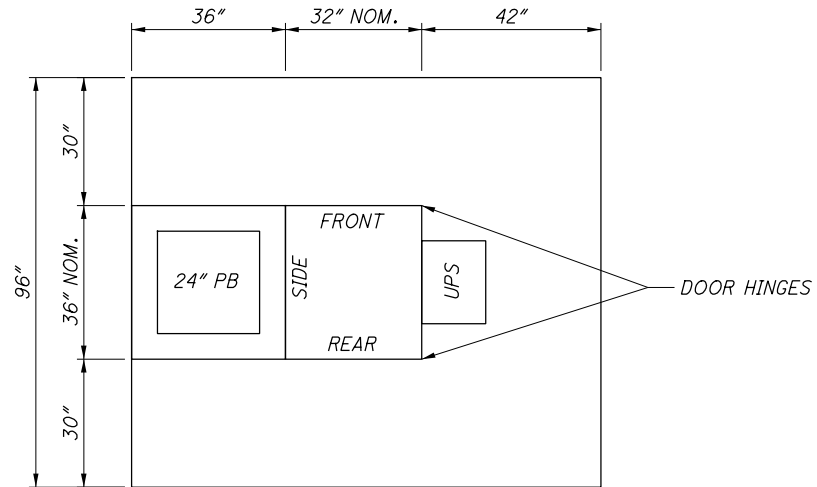

**MODEL 332L CABINET DETAIL**

**MAST ARM TABLE (TEM FIGURE 498-37 & 38)**

SUPPORT NO.	STATION	OFFSET	ELEVATION		SIGNAL SUPPORT DETAILS											ORIENTATION ANGLES FROM MAST ARM								
			A (Pavt. Elev.)	B (Top of Found.)	DESIGN TYPE	DESIGN NO.	POLE HEIGHT	ARM HEIGHT	L	L1	L2	L3	L4	P1	D1	MAST ARM ANGLE	STOP LINE RADAR DETECTOR ANGLE	PEDESTRIAN SIGNAL	POWER SERVICE	FACE OF POLE MOUNTED SIGN	POLE MOUNTED STREET NAME SIGN	HANDHOLE	CONDUIT ELLS	CABLE ENTRANCE 12\"/>
SP-1	143+69	50 LT	1092.85	1093.35	TC-81.22	13	21.5	20	53	-	31	43	49	25	36	0	60	0/270	135	270	-	180	40 / 40	135
SP-2	144+49	51 LT	1092.58	1093.14	TC-81.22	12	21.5	20	41	-	20	32	38	15	25	85	75	190/280	-	270	0/270	180	245 / 245	-
SP-3	144+73	42 RT	1092.95	1093.94	TC-81.22	12	21.5	20	45	-	25	36	42	20	30	0	45	180/270	-	270	-	180	65 / 65	-
SP-4	143+73	40 RT	1093.86	1094.15	TC-81.22	12	21.5	20	48	22	26	39	44	18	32	85	80	100/190	-	270	-	180	220 / 220	-

CALCULATED  
CWG  
CHECKED  
SAK

**TRAFFIC SIGNAL PLAN DETAILS  
STATE ROUTE 87 & STATE ROUTE 306**

**GEA-87-2.7.3**

**WIRING DIAGRAM (TYPICAL)**

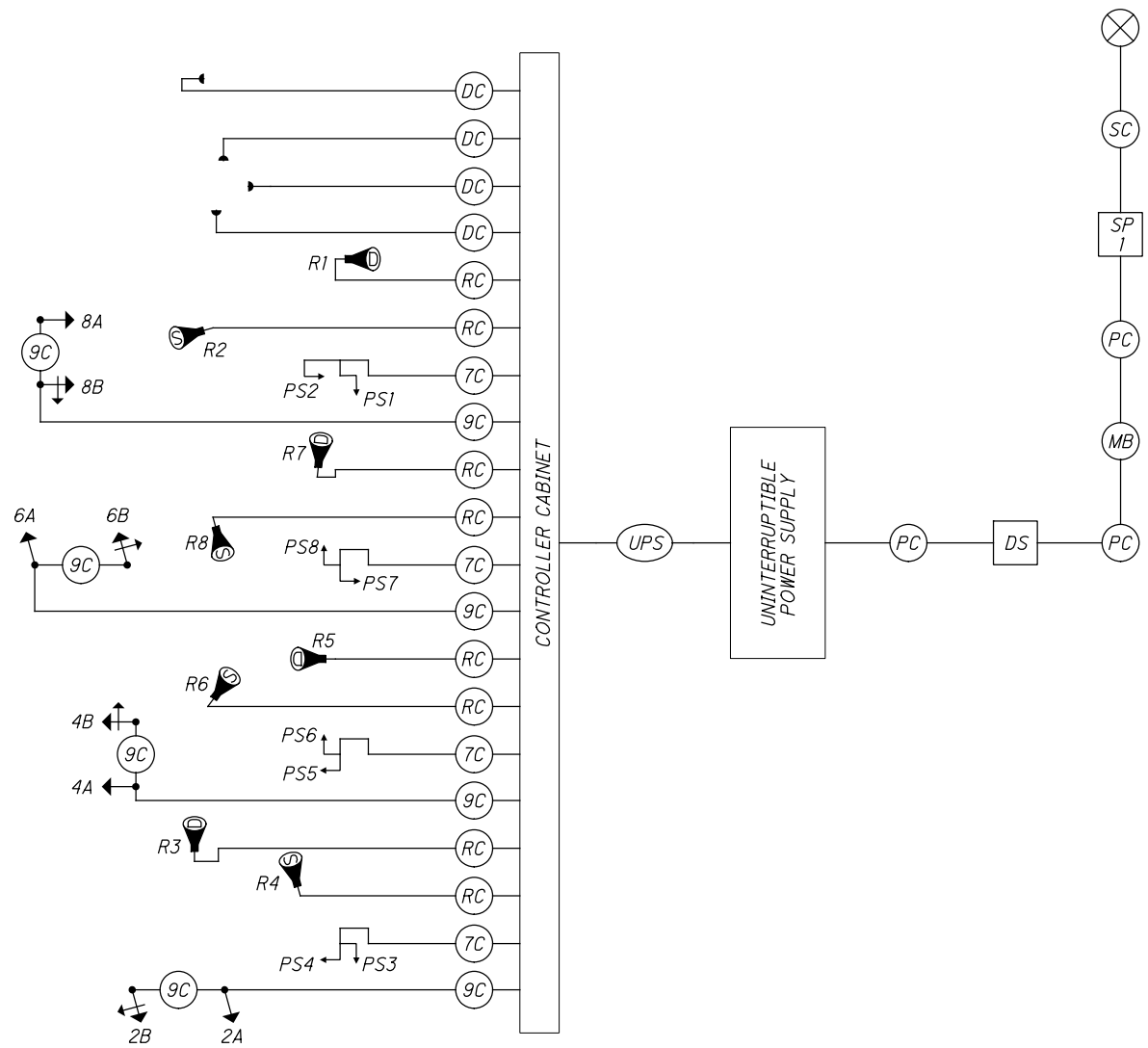

**NOTES:**  
- FOR LOCATIONS WITH LEFT TURN LANES  
RUN 7C FOR POTENTIAL PT/PM LT PHASE IF  
INITIAL DESIGN IS FOR PERMITTED ONLY.

**FIELD WIRING HOOK-UP CHART (TEM FORM 496-16)**

SIGNAL HEAD	INDICATION	FIELD TERMINAL	FLASH	SIGNAL HEAD	INDICATION	FIELD TERMINAL	FLASH
2A (NB)	R	φ2R	Y	8A (WB)	R	φ8R	R
	Y	φ2Y			Y	φ8Y	
	G	φ2G			G	φ8G	
2B (NB LT)	R	φ2R	Y	8B (WB LT)	R	φ8R	R
	Y	φ2Y			Y	φ8Y	
	G	φ2G			G	φ8G	
	<--Y---	φ5Y			<--Y---	φ3Y	
	<--G---	φ5G		<--G---	φ3G		
<b>PEDESTRIAN MOVEMENTS</b>							
4A (EB)	R	φ4R	R	PED A EAST	W	φ2 PED / LS 2P G	OUT
	Y	φ4Y			DW	φ2 PED / LS 2P R	
4B (EB LT)	R	φ4R	R	PED B SOUTH	W	φ4 PED / LS 4P G	OUT
	Y	φ4Y			DW	φ4 PED / LS 4P R	
6A (SB)	R	φ6R	Y	PED C WEST	W	φ6 PED / LS 6P G	OUT
	Y	φ6Y			DW	φ6 PED / LS 6P R	
6B (SB LT)	R	φ6R	Y	PED D NORTH	W	φ8 PED / LS 8P G	OUT
	Y	φ6Y			DW	φ8 PED / LS 8P R	
NO OVERLAPS							
LS = LOAD SWITCH							

**LEGEND**

	TRAFFIC SIGNAL, 4 OR 5 UNIT HEAD, 12"		SIGNAL CABLE, 7 CONDUCTOR, NO. 14 AWG		DISCONNECT SWITCH
	TRAFFIC SIGNAL, 2 UNIT, 3 UNIT, OR PHB HEAD 12"		SIGNAL CABLE, 9 CONDUCTOR, NO. 14 AWG		UNINTERRUPTIBLE POWER SUPPLY CABLE
	TRAFFIC SIGNAL, 3 UNIT HEAD, 12" WITH ARROWS		RADAR DETECTION CABLE		POWER SOURCE
	PEDESTRIAN SIGNAL		PREEMPTION DETECTOR CABLE		
	PREEMPTION DETECTOR		SERVICE CABLE, 3 CONDUCTOR, NO. 6 AWG		
	DILEMMA ZONE RADAR DETECTION UNIT		POWER CABLE, 2 CONDUCTOR, NO. 6 AWG		
	STOP LINE RADAR DETECTION UNIT		SIGNAL SUPPORT POLE NO. ...		
			METER BASE		

L:\ODOT\19068303-00\_VAR-D12-D03-SftyDsgn\02\_GEA-87\110882\_Roadway\Sheets\110882\_CP004.dgn 9/21/2020 11:04:50 AM ghansel

SEPAC AND ASC/3 INPUT FILE INFORMATION FOR THE 332 CABINET

UPPER INPUT FILE (FILE=I)

C U P P A N E N R E L	PHASE	1	2	2	2	3	4	4	4	1	MANUAL CONTROL ADV.	2	6	FLASH	
	DEFAULT FUNCTION	EXT-CALL	EXT-CALL	EXT-CALL	EXT-CALL	EXT-CALL	EXT-CALL	EXT-CALL	EXT-CALL	EXT-CALL	SPARE	PED	PED	SENSE	
	SEPAC DETECTOR NO.	VEH 1	VEH 3	VEH 5	VEH 7	VEH 9	VEH 11	VEH 13	VEH 15	VEH 17		PED 2	PED 6		
	ASC/3 DETECTOR NO.	VEH 1	VEH 2	VEH 3	VEH 4	VEH 5	VEH 6	VEH 7	VEH 8	VEH 9		PED 2	PED 6		
	C1 PIN NUMBER	56	39	63	47	58	41	65	49	60		80	67	68	81
FIELD TERMINALS	1-D,E	2-D,E	3-D,E	4-D,E	5-D,E	6-D,E	7-D,E	8-D,E	9-D,E	10-D,E	11-D,E	12-D,E	13-D,E	14-D,E	
SLOT NUMBER		1	2	3	4	5	6	7	8	9	10	11	12	13	14
C L H O W N E R E L	PHASE	1	2	2	2	3	4	4	4	3	ADV.	4	8	STOP	
	DEFAULT FUNCTION	EXT-CALL	EXT-CALL	EXT-CALL	EXT-CALL	EXT-CALL	EXT-CALL	EXT-CALL	EXT-CALL	EXT-CALL	SPARE	ENABLE	PED	PED	TIME
	SEPAC DETECTOR NO.	VEH 1	VEH 4	VEH 6	VEH 7	VEH 9	VEH 12	VEH 14	VEH 15	VEH 18			PED 4	PED 8	
	ASC/3 DETECTOR NO.	VEH 1	VEH 10	VEH 11	VEH 4	VEH 5	VEH 14	VEH 15	VEH 8	VEH 13			PED 4	PED 8	
	C1 PIN NUMBER	56	43	76	47	58	45	78	49	62		53	69	70	82
FIELD TERMINALS	1-J,K	2-J,K	3-J,K	4-J,K	5-J,K	6-J,K	7-J,K	8-J,K	9-J,K	10-J,K	11-J,K	12-J,K	13-J,K	14-J,K	

LOWER INPUT FILE (FILE=J)

C U P P A N E N R E L	PHASE	5	6	6	6	7	8	8	8	5	SPARE	SPARE	EV - A	EV - B	RR - 1
	DEFAULT FUNCTION	EXT-CALL	EXT-CALL	EXT-CALL	EXT-CALL	EXT-CALL	EXT-CALL	EXT-CALL	EXT-CALL	EXT-CALL	SPARE	SPARE			
	SEPAC DETECTOR NO.	VEH 19	VEH 21	VEH 23	VEH 25	VEH 29	VEH 31	VEH 33	VEH 35	VEH 37					
	ASC/3 DETECTOR NO.	VEH 17	VEH 18	VEH 19	VEH 20	VEH 21	VEH 22	VEH 23	VEH 24	VEH 25					
	C1 PIN NUMBER	55	40	64	48	57	42	66	50	59		54	71	72	51
FIELD TERMINALS	1-D,E	2-D,E	3-D,E	4-D,E	5-D,E	6-D,E	7-D,E	8-D,E	9-D,E	10-D,E	11-D,E	12-D,E	13-D,E	14-D,E	
SLOT NUMBER		1	2	3	4	5	6	7	8	9	10	11	12	13	14
C L H O W N E R E L	PHASE	5	6	6	6	7	8	8	8	7	SPARE	SPARE	EV - C	EV - D	RR - 2
	DEFAULT FUNCTION	EXT-CALL	EXT-CALL	EXT-CALL	EXT-CALL	EXT-CALL	EXT-CALL	EXT-CALL	EXT-CALL	EXT-CALL	SPARE	SPARE			
	SEPAC DETECTOR NO.	VEH 19	VEH 22	VEH 24	VEH 25	VEH 29	VEH 32	VEH 34	VEH 35	VEH 38					
	ASC/3 DETECTOR NO.	VEH 17	VEH 26	VEH 27	VEH 20	VEH 21	VEH 30	VEH 31	VEH 24	VEH 29					
	C1 PIN NUMBER	55	44	77	48	57	46	79	50	61		75	73	74	52
FIELD TERMINALS	1-J,K	2-J,K	3-J,K	4-J,K	5-J,K	6-J,K	7-J,K	8-J,K	9-J,K	10-J,K	11-J,K	12-J,K	13-J,K	14-J,K	

SEPAC AND ASC/3 INPUT FILE INFORMATION FOR THE 336 CABINET

C U P P A N E N R E L	PHASE	1	2	3	4	5	6	7	8	RR - 1	EV - A	EV - B	2	6	FLASH
	DEFAULT FUNCTION	EXT-CALL	EXT-CALL	EXT-CALL	EXT-CALL	EXT-CALL	EXT-CALL	EXT-CALL	EXT-CALL	RR - 1	EV - A	EV - B	PED	PED	SENSE
	SEPAC DETECTOR NO.	VEH 1	VEH 3	VEH 9	VEH 11	VEH 19	VEH 21	VEH 29	VEH 31				PED 2	PED 6	
	ASC/3 DETECTOR NO.	VEH 1	VEH 2	VEH 5	VEH 6	VEH 17	VEH 18	VEH 21	VEH 22				PED 2	PED 6	
	C1 PIN NUMBER	56	39	58	41	55	40	57	42	51	71	72	67	68	81
FIELD TERMINALS	1-D,E	2-D,E	3-D,E	4-D,E	5-D,E	6-D,E	7-D,E	8-D,E	9-D,E	10-D,E	11-D,E	12-D,E	13-D,E	14-D,E	
SLOT NUMBER		1	2	3	4	5	6	7	8	9	10	11	12	13	14
C L H O W N E N R E L	PHASE	2	2	4	4	6	6	8	8	RR - 2	EV - C	EV - D	4	8	STOP
	DEFAULT FUNCTION	EXT-CALL	EXT-CALL	EXT-CALL	EXT-CALL	EXT-CALL	EXT-CALL	EXT-CALL	EXT-CALL	RR - 2	EV - C	EV - D	PED	PED	TIME
	SEPAC DETECTOR NO.	VEH 7	VEH 4	VEH 15	VEH 12	VEH 25	VEH 22	VEH 35	VEH 32				PED 4	PED 8	
	ASC/3 DETECTOR NO.	VEH 4	VEH 10	VEH 8	VEH 14	VEH 20	VEH 26	VEH 24	VEH 30				PED 4	PED 8	
	C1 PIN NUMBER	47	43	49	45	48	44	50	46	52	73	74	69	70	82
FIELD TERMINALS	1-J,K	2-J,K	3-J,K	4-J,K	5-J,K	6-J,K	7-J,K	8-J,K	9-J,K	10-J,K	11-J,K	12-J,K	13-J,K	14-J,K	

L:\ODOT\19068303-00\_VAR-D12-D03-SftyDsgn\02\_GEA-87\110882\_Roadway\Sheets\110882\_CP005.dgn 9/21/2020 11:04:50 AM ghonsel

THIS DRAWING REPLACES PIS 203324 DATED 10-18-2013.

DESIGNED CWG	REVIEWED SAK	OFFICE OF ROADWAY ENGINEERING
PLAN INSERT SHEET		
SEPAC AND ASC/3 INPUT FILE INFORMATION FOR 332 AND 336 CABINETS		
GEA-87-2.73		
1 / 1		
12A 20		

SIGNAL SUBSUMMARY			
ITEM	QUAN.	UNIT	DESCRIPTION
625	122	FT	CONDUIT, 3", 725.04
625	281	FT	CONDUIT, JACKED OR DRILLED, 725.051, 4"
625	61	FT	TRENCH
625	3	EACH	PULL BOX, 725.08, 18"
625	10	EACH	PULL BOX REMOVED
625	5	EACH	GROUND ROD
625	61	FT	PLASTIC CAUTION TAPE
630	5	EACH	SIGN HANGER ASSEMBLY, MAST ARM, AS PER PLAN
630	4	EACH	SIGN SUPPORT ASSEMBLY, POLE MOUNTED
630	2	EACH	SIGN SUPPORT ASSEMBLY, POLE MOUNTED, AS PER PLAN
630	61	SF	SIGN, FLAT SHEET
630	2	EACH	SIGN, DOUBLE FACED, STREET NAME
632	4	EACH	VEHICULAR SIGNAL HEAD, (LED), 3-SECTION, 12" LENS, 1-WAY, POLYCARBONATE, BLACK, WITH BACKPLATE
632	4	EACH	VEHICULAR SIGNAL HEAD, (LED), 5-SECTION, 12" LENS, 1-WAY, POLYCARBONATE, BLACK, WITH BACKPLATE
632	8	EACH	PEDESTRIAN SIGNAL HEAD (LED), TYPE D2, COUNTDOWN, AS PER PLAN
632	8	EACH	COVERING OF VEHICULAR SIGNAL HEAD
632	8	EACH	COVERING OF PEDESTRIAN SIGNAL HEAD
632	610	FT	SIGNAL CABLE, 7 CONDUCTOR, NO. 14 AWG
632	650	FT	SIGNAL CABLE, 9 CONDUCTOR, NO. 14 AWG
632	4	EACH	SIGNAL SUPPORT FOUNDATION
632	240	FT	POWER CABLE, 2 CONDUCTOR, NO. 6 AWG
632	300	FT	SERVICE CABLE, 3 CONDUCTOR, NO. 6 AWG
632	1	EACH	POWER SERVICE
632	3	EACH	SIGNAL SUPPORT, TYPE TC-81.22, DESIGN 12, AS PER PLAN
632	1	EACH	SIGNAL SUPPORT, TYPE TC-81.22, DESIGN 13, AS PER PLAN
632	1	EACH	REMOVAL OF TRAFFIC SIGNAL INSTALLATION
633	1	EACH	CABINET, TYPE 332L, AS PER PLAN
633	1	EACH	CABINET FOUNDATION
633	1	EACH	CONTROLLER WORK PAD, AS PER PLAN
633	1	EACH	COMMUNICATIONS, AS PER PLAN
633	1	EACH	UNINTERRUPTIBLE POWER SUPPLY (UPS), 1000 WATT, AS PER PLAN
809	4	EACH	ADVANCE RADAR DETECTION, AS PER PLAN
809	4	EACH	STOP LINE RADAR DETECTION, AS PER PLAN
809	1	EACH	ATC V6.24 CONTROLLER, AS PER PLAN
809	4	EACH	EMERGENCY VEHICLE PREEMPTION
809	4	EACH	PREEMPT RECEIVING UNIT
809	730	FT	PREEMPT DETECTOR CABLE
809	1	EACH	PREEMPT PHASE SELECTOR
809	4	EACH	PREEMPT CONFIRMATION LIGHT, LED

# RIGHT OF WAY LEGEND SHEET

## GEA-87-2.73 (KINSMAN ROAD)

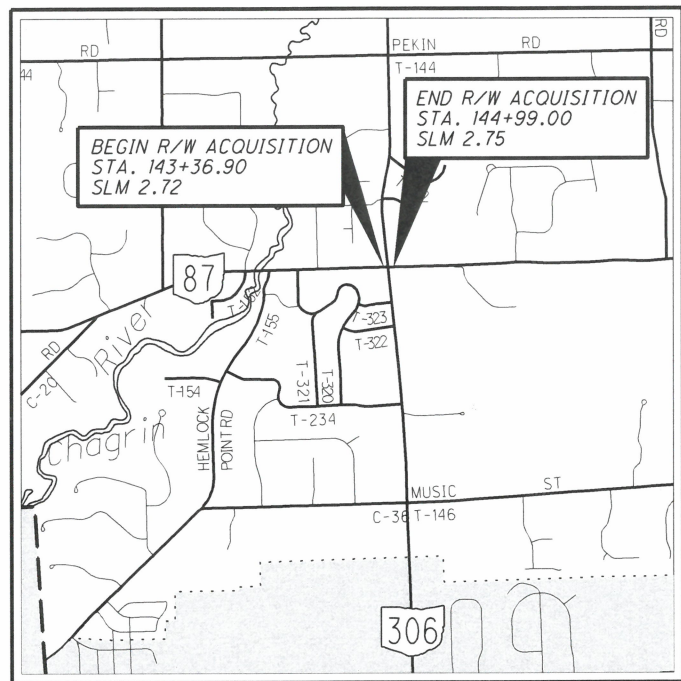

**LOCATION MAP**  
LATITUDE: 41°27'50" LONGITUDE: 81°20'25"

GEAUGA COUNTY  
RUSSELL TOWNSHIP  
ORIGINAL LOTS NO. 2, 4, 5 & 6  
CENTER DIVISION TRACT 2  
T7N, R9W  
CONNECTICUT WESTERN RESERVE

### PROJECT DESCRIPTION

THIS PROJECT WILL REPLACE THE EXISTING SIGNAL SYSTEM, AND PROVIDE COUNTDOWN PEDESTRIAN SIGNAL HEADS AT THE INTERSECTION OF S.R. 87 AND S.R. 306.

### PROJECT CONTROL

THE COORDINATES REFERENCED HEREIN ARE OHIO STATE PLANE GRID COORDINATE NAD (2011) NORTH ZONE COORDINATES IN U.S. SURVEY FEET.

### PARCEL LEGEND

SH = STANDARD HIGHWAY EASEMENT

### PLANS PREPARED BY:

FIRM NAME : ENGINEERING ASSOCIATES, INC.  
R/W DESIGNER: MICHELLE D. GALEHOUSE  
R/W REVIEWER: WILLIAM D. THOMAS, P.S.  
FIELD REVIEWER: JOSHUA RAKOSKY, C.S.T.  
PRELIMINARY FIELD REVIEW DATE: 5/11/2020  
TRACINGS FIELD REVIEW DATE: 7/16/2020  
OWNERSHIP UPDATED BY: WILLIAM D. THOMAS  
DATE COMPLETED: 7/15/2020  
PLAN COMPLETION DATE: 7/23/2020

### CONVENTIONAL SYMBOLS

County Line	Ownership Hook Symbol	Example
Township Line	Property Line Symbol	Example
Lot Line & Section Line	Break Line Symbol	Example
Corporation Line	Tree (Pr)	Tree (Ex), Shrub (Ex)
Fence Line (Ex)	Tree (Remove)	Shrub (Remove)
Center Line	Evergreen (Ex)	Stump
Right of Way (Ex)	Evergreen (Remove)	Stump (Remove)
Right of Way (Pr)	Wetland (Pr)	Grass (Pr), Aerial Target
Standard Highway Ease. (Ex)	Post (Ex)	Mailbox (Ex), Mailbox (Pr)
Temporary Right of Way	Light (Ex)	Telephone Marker (Ex) TEL
Channel Ease. (Pr)	Fire Hydrant (Ex)	Water Meter (Ex)
Utility Ease. (Ex)	Water Valve (Ex)	Utility Valve Unknown (Ex.)
Railroad	Telephone Pole (Ex)	Power Pole (Ex)
Guardrail (Ex)	Light Pole (Ex)	
Construction Limits	Electric Line (Ex)	
Edge of Pavement (Ex)	Telephone Line (Ex)	
Edge of Pavement (Pr)	Cable Line (Ex)	
Edge of Shoulder (Ex)	Gas Line (Ex)	
Edge of Shoulder (Pr)	Fiber Optic Line (Ex)	
Ditch / Creek (Ex)	Sanitary Sewer (Ex)	
Ditch / Creek (Pr)	Water Line (Ex)	
Tree Line (Ex)	Storm Sewer (Ex)	

### STRUCTURE KEY

	RESIDENTIAL
	COMMERCIAL
	OUT-BUILDING

### INDEX OF SHEETS:

LEGEND SHEET	1
CENTERLINE PLAT	2-3
PROPERTY MAP	4
SUMMARY OF RIGHT OF WAY	5
R/W TOPO SHEET	6
R/W BOUNDARY SHEET	7

UTILITY OWNERS			
<b>ELECTRIC:</b>	ILLUMINATING COMPANY ATTN: JOHN M. ZASSICK 6896 MILLER RD, SUITE 101 BRECKSVILLE, OHIO 44141 440-546-8706	<b>GAS:</b>	DOMINION ENERGY OHIO ATTN: MICAH J. RISACHER 320 SPRINGSIDE DR., SUITE 320 AKRON, OH 44333 330-664-2409
<b>FIBER OPTIC:</b>	NORTHEASTERN ITS ATTN: JOHN BRUCE 140 WINTER LANE CORTLAND, OH 44410 877-601-7662	<b>SEWER:</b>	GEAUGA COUNTY WATER RESOURCES ATTN: GERARD R. MORGAN 470 CENTER STREET, BUILDING #3 CHARDON, OHIO 44024 440-279-1970
	WINDSTREAM ATTN: GEOFFREY HAMM 560 TERNES AVENUE ELYRIA, OHIO 44035 440-329-4245		
	ODOT 12 TRAFFIC 5500 TRANSPORTATION BLVD GARFIELD HEIGHTS, OH 44125 216-581-2100		

NOTES: THE LOCATION OF THE UNDERGROUND UTILITIES SHOWN ON THE PLANS ARE OBTAINED FROM THE OWNER OF THE UTILITIES AS REQUIRED BY SECTION 153.64 O.R.C.

I, WILLIAM D. THOMAS, P. S. HAVE CONDUCTED A SURVEY OF THE EXISTING CONDITIONS FOR THE OHIO DEPARTMENT OF TRANSPORTATION IN SEPTEMBER 2019 THE RESULTS OF THAT SURVEY ARE CONTAINED HEREIN.

UNDERGROUND UTILITY LOCATIONS ARE SHOWN FOR INFORMATIONAL PURPOSES ONLY. THOUGH THEY ARE BELIEVED TO BE ACCURATE, THEIR LOCATION IS AS MARKED ON THE GROUND BY THE UTILITY COMPANY PER OUPS CONFIRMATION NUMBERS B926300279-00B AND B826300283-00B, AND THOSE MARKINGS SUBSEQUENTLY BEING SURVEYED AS A PART OF THIS PROJECT.

THE HORIZONTAL COORDINATES EXPRESSED HEREIN ARE BASED ON OHIO STATE PLANE NORTH ZONE (3401) GRID COORDINATES AND FROM A GPS SURVEY PERFORMED IN SEPTEMBER 2019 BY ENGINEERING ASSOCIATES, INC.

AS A PART OF THIS PROJECT I HAVE REESTABLISHED THE LOCATION OF THE EXISTING PROPERTY LINES AND THE CENTERLINE OF RIGHT OF WAY FOR PROPERTY TAKES CONTAINED HEREIN. AS A PART OF THIS PROJECT I HAVE ESTABLISHED THE PROPOSED PROPERTY LINES, CALCULATED THE GROSS TAKE, PRESENT ROADWAY OCCUPIED (PRO), NET TAKE AND NET RESIDUE; AS WELL AS PREPARED THE LEGAL DESCRIPTIONS NECESSARY TO ACQUIRE THE PARCELS AS SHOWN HEREIN. AS A PART OF THIS WORK I HAVE SET RIGHT OF WAY MONUMENTS AT THE PROPERTY CORNERS, ANGLE POINTS ON THE RIGHT OF WAY, AND OTHER POINTS AS SHOWN HEREIN.

ALL OF MY WORK CONTAINED HEREIN WAS CONDUCTED IN ACCORDANCE WITH OHIO ADMINISTRATIVE CODE 4733-37 COMMONLY KNOWN AS "MINIMUM STANDARDS FOR BOUNDARY SURVEYS IN THE STATE OF OHIO" UNLESS NOTED. THE WORDS I AND MY AS USED HEREIN ARE TO MEAN EITHER MYSELF OR SOMEONE WORKING UNDER MY DIRECT SUPERVISION.

*William D. Thomas*  
PROFESSIONAL LAND SURVEYOR 7590

07/23/2020  
DATE:

SURVEYORS SEAL:



SIGNED *William D. Thomas*  
DATE: 07/23/2020

FEDERAL PROJECT NO.  
E191(631)

PID NO.  
110882

CALCULATED  
MDG  
CHECKED  
WDT

RIGHT OF WAY  
LEGEND SHEET

GEA-87-2.73

1 / 7

14  
20

# GEA-87-2.73 (KINSMAN ROAD)

GEAUGA COUNTY  
RUSSELL TOWNSHIP  
ORIGINAL LOTS NO. 2,4,5 & 6  
CENTER DIVISION TRACT 2  
T7N, R9W  
CONNECTICUT WESTERN RESERVE



PID NO. **110882**

R/W DESIGNER: MDG  
R/W REVIEWER: WDT

CENTERLINE PLAT

GEA-87-2.73

1/2  
2/7

15  
20

- MONUMENT LEGEND**
- ☒ EXISTING R/W MONUMENT BOX
  - ☒ PROPOSED R/W MONUMENT BOX
  - ⊙ EXISTING CONCRETE MONUMENT
  - PROPOSED CONCRETE MONUMENT
  - ⚡ RAILROAD SPIKE FOUND
  - ⚡ RAILROAD SPIKE SET
  - ⊙ I.P.F. IRON PIN FOUND
  - ⊙ I.P.F. IRON PIN FOUND W/ ID CAP
  - I.P.S. IRON PIN SET W/ ID CAP
  - ⊙ I.P.F. IRON PIPE FOUND
  - ⊙ I.P.S. IRON PIPE SET
  - ⊙ P.K.F. P.K. NAIL FOUND
  - P.K.S. P.K. NAIL SET

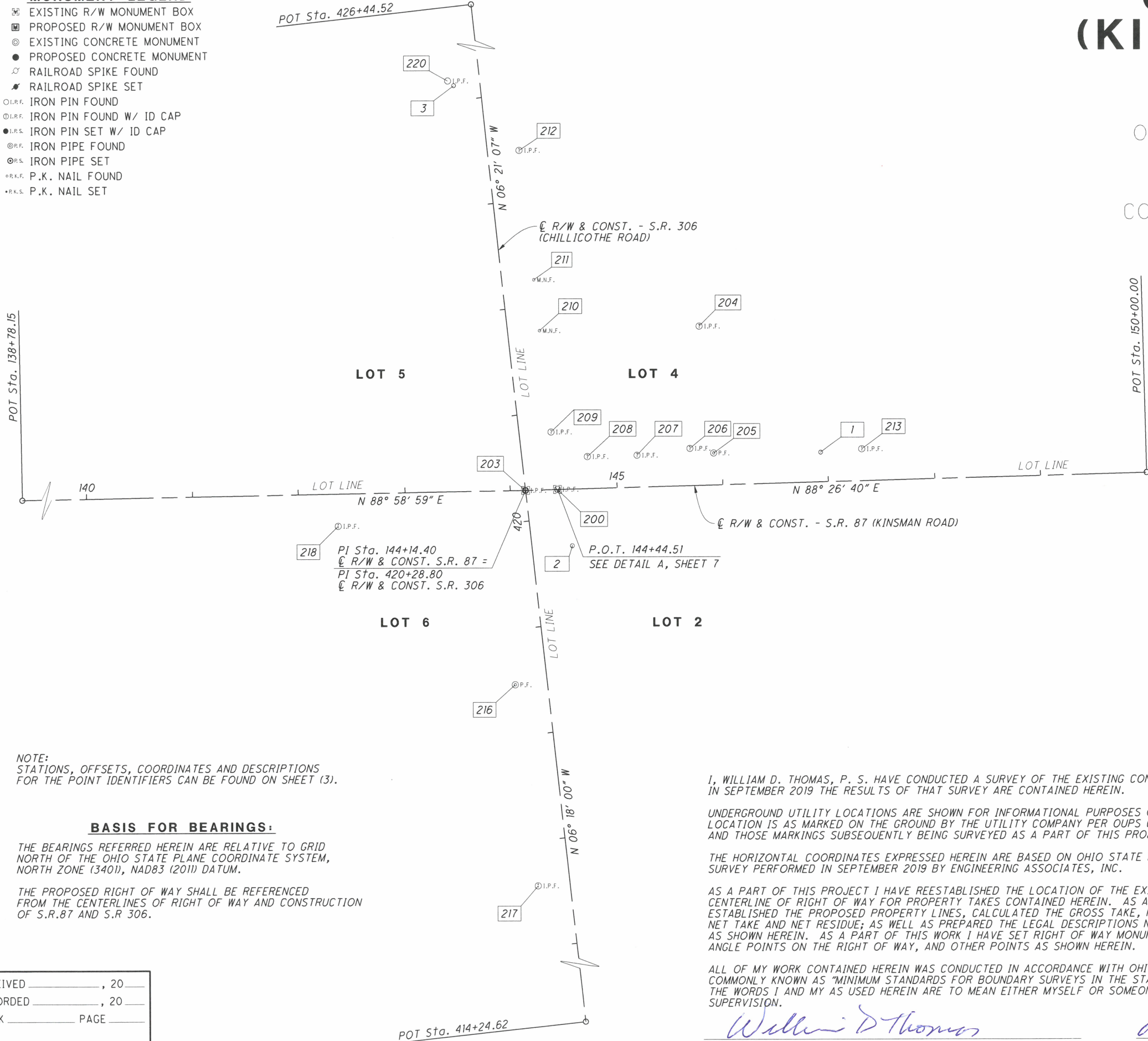

**BASIS OF RIGHT OF WAY:**  
THE CENTERLINE OF RIGHT OF WAY AND THE RIGHT OF WAY WIDTHS ARE BASED ON STATE OF OHIO PLANS.

- MENTOR-ON-THE-LAKE-AURORA ROAD  
S.H. NO. 651, SECTIONS E & F, 1939
- GEA-306-7.96, 1956
- GEA-87-(2.74)(3.25)(6.86), 1953
- ADDITIONAL REFERENCES:  
DEDICATION PLAT OF SANITARY SEWER EASEMENT  
PV 42, PG 18, 2014
- GREAT LAKES REGION RAZE & REBUILD PLANS  
FOR CIRCLE K STORE #5277, 2019

**NOTE:**  
STATIONS, OFFSETS, COORDINATES AND DESCRIPTIONS FOR THE POINT IDENTIFIERS CAN BE FOUND ON SHEET (3).

**BASIS FOR BEARINGS:**

THE BEARINGS REFERRED HEREIN ARE RELATIVE TO GRID NORTH OF THE OHIO STATE PLANE COORDINATE SYSTEM, NORTH ZONE (3401), NAD83 (2011) DATUM.

THE PROPOSED RIGHT OF WAY SHALL BE REFERENCED FROM THE CENTERLINES OF RIGHT OF WAY AND CONSTRUCTION OF S.R.87 AND S.R.306.

I, WILLIAM D. THOMAS, P. S. HAVE CONDUCTED A SURVEY OF THE EXISTING CONDITIONS FOR THE OHIO DEPARTMENT OF TRANSPORTATION IN SEPTEMBER 2019 THE RESULTS OF THAT SURVEY ARE CONTAINED HEREIN.

UNDERGROUND UTILITY LOCATIONS ARE SHOWN FOR INFORMATIONAL PURPOSES ONLY. THOUGH THEY ARE BELIEVED TO BE ACCURATE, THEIR LOCATION IS AS MARKED ON THE GROUND BY THE UTILITY COMPANY PER OUPS CONFIRMATION NUMBERS B926300279-00B AND B826300283-00B, AND THOSE MARKINGS SUBSEQUENTLY BEING SURVEYED AS A PART OF THIS PROJECT.

THE HORIZONTAL COORDINATES EXPRESSED HEREIN ARE BASED ON OHIO STATE PLANE NORTH ZONE (3401) GRID COORDINATES AND FROM A GPS SURVEY PERFORMED IN SEPTEMBER 2019 BY ENGINEERING ASSOCIATES, INC.

AS A PART OF THIS PROJECT I HAVE REESTABLISHED THE LOCATION OF THE EXISTING PROPERTY LINES AND THE CENTERLINE OF RIGHT OF WAY FOR PROPERTY TAKES CONTAINED HEREIN. AS A PART OF THIS PROJECT I HAVE ESTABLISHED THE PROPOSED PROPERTY LINES, CALCULATED THE GROSS TAKE, PRESENT ROADWAY OCCUPIED (PRO), NET TAKE AND NET RESIDUE; AS WELL AS PREPARED THE LEGAL DESCRIPTIONS NECESSARY TO ACQUIRE THE PARCELS AS SHOWN HEREIN. AS A PART OF THIS WORK I HAVE SET RIGHT OF WAY MONUMENTS AT THE PROPERTY CORNERS, ANGLE POINTS ON THE RIGHT OF WAY, AND OTHER POINTS AS SHOWN HEREIN.

ALL OF MY WORK CONTAINED HEREIN WAS CONDUCTED IN ACCORDANCE WITH OHIO ADMINISTRATIVE CODE 4733-37 COMMONLY KNOWN AS "MINIMUM STANDARDS FOR BOUNDARY SURVEYS IN THE STATE OF OHIO" UNLESS NOTED. THE WORDS I AND MY AS USED HEREIN ARE TO MEAN EITHER MYSELF OR SOMEONE WORKING UNDER MY DIRECT SUPERVISION.

*William D Thomas*  
PROFESSIONAL LAND SURVEYOR 7590

07/23/2020  
DATE:

SURVEYORS SEAL:



SIGNED *William D Thomas*  
DATE: 07/23/2020

M:\1906\GEA-87-2.73 - Kinsman Road and SR 306\110882\Design\RM\Sheets\110882.RC001.dgn 7/22/2020 11:03:11 AM kja282

RECEIVED \_\_\_\_\_, 20  
RECORDED \_\_\_\_\_, 20  
BOOK \_\_\_\_\_ PAGE \_\_\_\_\_  
COUNTY RECORDER

CALCULATED  
KJA  
CHECKED  
WDT

STATE PLANE GRID COORDINATES - US SURVEY FEET								PROJECT CONTROL POINTS	
C/L of Right-of-Way SR 87-			GEA-87-(2.74) (3.25) (6.86) S.H.No 651 SEC E&F used for alignment						
NAME	STATION	OFFSET (US FT)	RT/LT	NORTH (US FT)	EAST (US FT)	ELEVATION (US FT)	FEATURE	DESCRIPTION	
<b>CL RW 87</b>									
1	146+93.48	-27.86	LT	656455.812	2286711.104	1086.12	CNPT	5/8" REBAR W/YELLOW CAP STAMPED CONTROL POINT	
2	144+56.87	53.20	RT	656368.359	2286476.789	1093.57	CNPT	5/8" REBAR W/YELLOW CAP STAMPED CONTROL POINT	
3	143+53.64	-381.22	LT	656800.465	2286365.376	1083.26	CNPT	5/8" REBAR W/YELLOW CAP STAMPED CONTROL POINT	
<b>CL RW 306</b>									
1	420+33.23	280.43	RT	656455.812	2286711.104	1086.12	CNPT	5/8" REBAR W/YELLOW CAP STAMPED CONTROL POINT	
2	419+72.27	37.93	RT	656368.359	2286476.789	1093.57	CNPT	5/8" REBAR W/YELLOW CAP STAMPED CONTROL POINT	
3	424+14.02	-25.05	LT	656800.465	2286365.376	1083.26	CNPT	5/8" REBAR W/YELLOW CAP STAMPED CONTROL POINT	

EXISTING MONUMENTATION & CENTERLINE OF RIGHT OF WAY STATE ROUTE 87 & 306								EXISTING CENTERLINE CONTROL POINTS	
NAME	STATION	OFFSET (US FT)	RT/LT	NORTH (US FT)	EAST (US FT)	ELEVATION (US FT)	FEATURE	DESCRIPTION	
<b>CL RW 87</b>									
200	144+44.52	-0.07	LT	656421.273	2286462.997	1092.26	IPIN	5/8 REBAR IN MONUMENT BOX	
203	144+14.40	0.00	CL	656420.384	2286432.888	1092.29	IPIN	1 REBAR IN MONUMENT BOX	
205	145+92.08	-30.03	LT	656455.231	2286609.688	1089.60	IPIPE	3/4 BENT IRON PIPE	
206	145+69.64	-35.01	LT	656459.600	2286587.118	1091.62	IPID	IRON PIN W/CAP STAMPED WELLERT CORP	
207	145+19+63	-30.03	LT	656453.255	2286537.265	1092.10	IPID	IRON PIN W/CAP STAMPED WELLERT CORP	
208	144+73.30	-30.00	LT	656451.977	2286490.954	1092.55	IPID	IRON PIN W/CAP STAMPED WELLERT CORP	
209	144+40.00	-54.17	LT	656475.225	2286457.012	1092.16	IPID	IRON PIN W/CAP STAMPED WELLERT CORP	
213	147+32.13	-29.88	LT	656458.880	2286749.687	1085.04	IPID	IRON PIN W/CAP STAMPED CT CONSULTANTS	
218	142+36.77	30.28	RT	656386.952	2286255.828	1088.61	IPID	IRON PIN W/CAP STAMPED MCSTEEN	
<b>CL RW 306</b>									
204	421+63.75	179.39	RT	656574.353	2286596.250	1090.40	IPID	IRON PIN W/CAP STAMPED WELLERT CORP	
210	421+76.45	30.09	RT	656570.454	2286446.457	1089.82	MAG		
211	422+24.56	30.05	RT	656618.263	2286441.092	1088.65	MAG		
212	423+46.69	29.99	RT	656739.637	2286427.529	1086.62	IPID	IRON PIN W/CAP STAMPED WELLERT CORP	
216	418+48.29	-29.99	LT	656237.677	2286422.891	1094.18	IPIPE	1" IRON PIPE HELD FOR S. PROPERTY LINE PARCEL 2	
217	416+57.82	-29.98	LT	656048.358	2286443.800	1091.99	IPID	IRON PIN W/CAP STAMPED SCHWART	
219	426+18.20	-30.07	LT	657002.836	2286337.790	1081.11	IPIPE	1.25" IRON PIPE	
220	424+19.06	-30.13	LT	656804.917	2286359.769	1082.54	IPIN	3/4" BAR	
221	426+44.52	30.02	RT	657035.647	2286394.601	1081.02	IPIN	1/2" BAR	
222	414+27.91	-29.82	LT	655819.851	2286469.188	1095.50	IPID	IRON PIN W/CAP STAMPED SCHWART	

CENTERLINE OF RIGHT OF WAY & CONSTRUCTION STATE ROUTE 87 & 306								CENTERLINE ALIGNMENT	
NAME	STATION	OFFSET (US FT)	RT/LT	NORTH (US FT)	EAST (US FT)	ELEVATION (US FT)	FEATURE	DESCRIPTION	
<b>CL RW 87</b>									
POT	138+78.15	0.00	CL	656410.8677	2285896.7224				
PI	144+14.40	0.00	CL	656410.3842	2286432.8880		IPIN	1" REBAR IN MONUMENT BOX, INTERSECTION S.R. 87 AND S.R. 306	
POT	144+44.51	0.00	CL					SEE DETAIL "A", SHEET 7	
POT	150+00.00	0.00	CL	656436.2809	2287018.2722				
<b>CL RW 306</b>									
POT	414+24.62	0.00	CL	655819.8508	2286499.1882				
PI	420+28.80	0.00	CL	656420.3842	2286432.8880		IPIN	1" REBAR IN MONUMENT BOX, INTERSECTION S.R. 87 AND S.R. 306	
POT	426+44.52	0.00	CL	657032.3276	2286364.7674				

PROPOSED RIGHT OF WAY MONUMENTS								
C/L of Right-of-Way SR 87-			GEA-87-(2.74) (3.25) (6.86) S.H.No 651 SEC E&F used for alignment					
NAME	STATION	OFFSET (US FT)	RT/LT	NORTH (US FT)	EAST (US FT)	ELEVATION (US FT)	FEATURE	DESCRIPTION
8001	143.36.90	30.00	RT	656389.0135	2286355.9301		IPINS	3/4" REBAR W/2" ALUMINUM CAP MARKED "ODOT R/W ENGINEERING ASSOCIATES 7590"
8002	143+91.66	79.94	RT	656340.0576	2286411.5740		IPINS	3/4" REBAR W/2" ALUMINUM CAP MARKED "ODOT R/W ENGINEERING ASSOCIATES 7590"
8003	421+13.40	30.00	RT	656507.7876	2286453.3437		IPINS	3/4" REBAR W/2" ALUMINUM CAP MARKED "ODOT R/W ENGINEERING ASSOCIATES 7590"
8004	144+99.00	30.00	LT	656452.6698	2286516.6461		IPINS	3/4" REBAR W/2" ALUMINUM CAP MARKED "ODOT R/W ENGINEERING ASSOCIATES 7590"

CENTERLINE PLAT

GEA-87-2.73

2 / 2  
3 / 7  
16  
20

M:\1906\GEA-87-2.73 - Kinsman Road and SR 306\10882\Design\RW\Sheets\10882\_RCO02.dgn 8/25/2020 9:37:53 AM mgg2ll



**TOTAL NUMBER OF :**

2 OWNERSHIPS 0 TOTAL TAKES  
 2 PARCELS 0 OWNERSHIPS W/ STRUCTURES INVOLVED

NET TAKE = GROSS TAKE - PRO IN TAKE  
 NET RESIDUE = RECORD AREA - TOTAL PRO - NET TAKE  
 ALL AREAS IN ACRES UNLESS OTHERWISE STATED

**GRANTEE:**

ALL RIGHT OF WAY ACQUIRED IN THE NAME OF  
 THE STATE OF OHIO DEPARTMENT OF TRANSPORTATION  
 UNLESS OTHERWISE SHOWN.

PARCEL NO.	OWNER	SHEET NO.	OWNERS RECORD		AUDITOR'S PARCEL	RECORD AREA	TOTAL P.R.O.	GROSS TAKE	P.R.O. IN TAKE	NET TAKE	STRUC-TURE	NET RESIDUE		TYPE FUND	REMARKS	AS ACQUIRED	
			BOOK	PAGE								LEFT	RIGHT			BOOK	PAGE
1	THE TRUSTEES OF RUSSELL TOWNSHIP, GEAUGA COUNTY, OHIO	6,7	DV 112	569	26-703000	0.500	0.178	0.000		0.000				STATE	PART OF LOT 5, CENTER DIVISION OF TRACT 2		
			DV 524	871	26-702900	0.380	0.066	0.000		0.000				100%	NO TAKE		
	TOTAL					0.880	0.244	0.000		0.000		0.636					
2SH	TOTABLE INTELLIGENCE, INC., AN OHIO CORPORATION	6,7	OR 2085	3190	26-191360	0.750	0.230	0.012	0.000	0.012	S(1)		0.508		PART OF LOT 6, CENTER DIVISION OF TRACT 2 LEASE TO HEMLOCK POINT VENTURES, LLC OR 1838, PG 613 REMOVE PRIVATE SHELL GAS STATION SIGN W/ELECTRIC 30 BUSHES, 2 STEEL LIGHT POLES NOT IN TAKE AREA		
3SH	RUSSELL TOWNSHIP BOARD OF TRUSTEES	6,7	OR 1807	2120	26-707049	0.410	0.000	0.009	0.000	0.009	NO		0.401		PART OF LOT 4, CENTER DIVISION OF TRACT 2  MULTIPLE USE AND OPERATING RESTRICTIONS ON THE DEED SEE EXHIBIT "B" IN DEED FOR RESTRICTIONS  CURRENT DEED DOES NOT INCLUDE PRO PARCEL 3SH OVERLAPS EX. SEWER EASEMENT PER PV 42, PG 18 & 19 BY 0.009 AC	202000973205	
4	BOARD OF TOWNSHIP TRUSTEES OF RUSSELL TOWNSHIP	6,7	DV 802	46	26-707000	0.740	0.276						0.464		PART OF LOT 2, CENTER OF DIVISION OF TRACT 2 NO TAKE		
5	OWNER UNKNOWN	6,7			NO AUDITOR PARCEL NO.		0.227								NO TAKE, EXISTING PRO ONLY		

NOTE: ALL TEMPORARY PARCELS TO BE OF 6 MONTH DURATION.

UNDER NO CIRCUMSTANCES ARE TEMPORARY EASEMENTS TO BE USED FOR STORAGE OF MATERIAL OR EQUIPMENT BY THE CONTRACTOR UNLESS NOTED OTHERWISE.

PARCEL LEGEND:  
 SH = STANDARD HIGHWAY EASEMENT

DOCUMENT LEGEND:  
 DV = DEED VOLUME  
 OR = OFFICIAL RECORD  
 PV = PLAT VOLUME

\* DENOTES R/W ENCROACHMENT

REV. BY	DATE	DESCRIPTION
FIELD REVIEW BY: J. RAKOSKY, C.S.T.		DATE: 7/16/2020
OWNERSHIP VERIFIED BY: WILLIAM D. THOMAS		DATE: 7/15/2020
DATE COMPLETED: 7/23/2020		

FEDERAL PROJECT NO. E191(631)  
 PID NO. 110882  
 STATE JOB NO. 527723  
 R/W DESIGNER MDG  
 R/W REVIEWER WDT  
**SUMMARY OF ADDITIONAL RIGHT OF WAY**  
 GEA-87-2.73  
 5 / 7  
 18  
 20

M:\19061\GEA-87-2.73 - Kinsman Road and SR 306\110882\Design\RW\Sheets\110882\_RS001.dgn 8/25/2020 9:37:55 AM mdg211



